

Active Liquid Tanks Specification Sheet



PTC00400FG

400 litre Free Standing Cartage Tank

Unit Specifications

Item	Description	Details
Tank	400 litre	UV stabilised polyethylene specially formulated for transport tanks. Complies with AS2070:1999 & AS4766:2006 compliant. Food grade with 10 year guarantee.
Lid	255mm	255mm threaded lid assembly with fixed labyrinth breather valve made to current anti-pollution standards with double breather valve to empty tank quickly with closed lid even with high delivery pump
Tank outlet	1 1/2" MBSP	Flanged polypropylene tank outlet fitting complete with nut & washer
Dimensions	PTC00400FG	1190mm(L) x 1050mm(W) x 500mm(H)
Dry weight		28kg
Baffles	Integral	Integral foam filled baffle
Colour		Faint green
Load Rating		1.3 Specific Gravity (SG)
Mounting	4 x 18 x 200mm Tank Mounting Pins	Mounts directly to any flat surface with galvanised steel mounting pins (optional)

1

Active Liquid Tanks Specification Sheet

Features

- Unconditional guarantee against rust
- Extraordinary impact resistance
- Impressive range of 'flex' to cope with chassis movement and twisting in tough operating conditions
- Calibrated for measurement of contents
- Mounts directly to any flat surface
- Spill containment lip surrounds lid
- Australian made for Australian conditions
- Optional tank colours available

For Use

- Potable (drinking water delivery)
- Dust suppression units
- Liquid fertiliser transport
- Water supply for spraying contractors
- Drillers mud
- Molasses transport

Dimensional Drawing – PTC00400FG

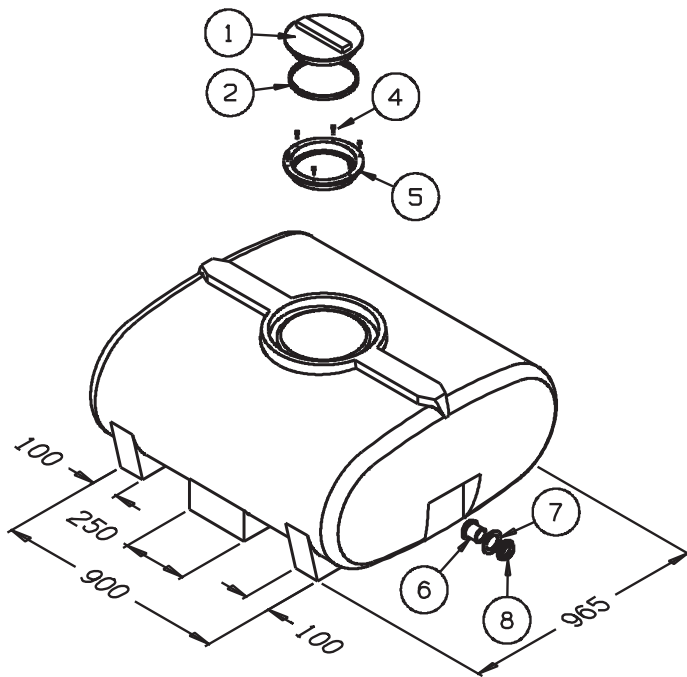

OVERALL DIMENSIONS 1190(L) X 1050(W) X 500(H)

ITEM	CODE	Description
1,2,5	ARLP250VSR	ø255 Lid Assembly
4		Stainless Steel Screws
6,7,8	ARFP038	1 1/2" MBSP Fitting Poly

2

*Rapid spray warranty requires fitting the Ball Baffle System to tanks larger than 6000 litres partially filled