

# Active Liquid Tanks Specification Sheet



PTC00600AFG

## 600 litre Squat Free Standing Cartage Tank

### Unit Specifications

Item	Description	Details
Tank	600 litre	UV stabilised polyethylene specially formulated for transport tanks. Complies with AS2070:1999 & AS4766:2006 compliant. Food grade with 10 year guarantee.
Lid	255mm	255mm threaded lid assembly with fixed labyrinth breather valve made to current anti-pollution standards with double breather valve to empty tank quickly with closed lid even with high delivery pump
Tank outlet	3/4"	3/4" poly drain bung & seal
Dimensions	PTC00600AFG	1420mm(L) x 1000mm(W) x 610mm(H)
Dry weight		38kg
Baffles		No baffle
Colour		Faint green
Load Rating		1.3 Specific Gravity (SG)
Mounting	M10 Brass Inserts	4 x threaded M10 brass inserts in base of tank

1

# Active Liquid Tanks Specification Sheet

## Features

- Unconditional guarantee against rust
- Extraordinary impact resistance
- Impressive range of 'flex' to cope with chassis movement and twisting in tough operating conditions
- Calibrated for measurement of contents
- Mounts directly to any flat surface
- Spill containment lip surrounds lid
- Australian made for Australian conditions
- Optional tank colours available

## For Use

- Potable (drinking water delivery)
- Dust suppression units
- Liquid fertiliser transport
- Water supply for spraying contractors
- Drillers mud
- Molasses transport

## Dimensional Drawing – PTC00600AFG

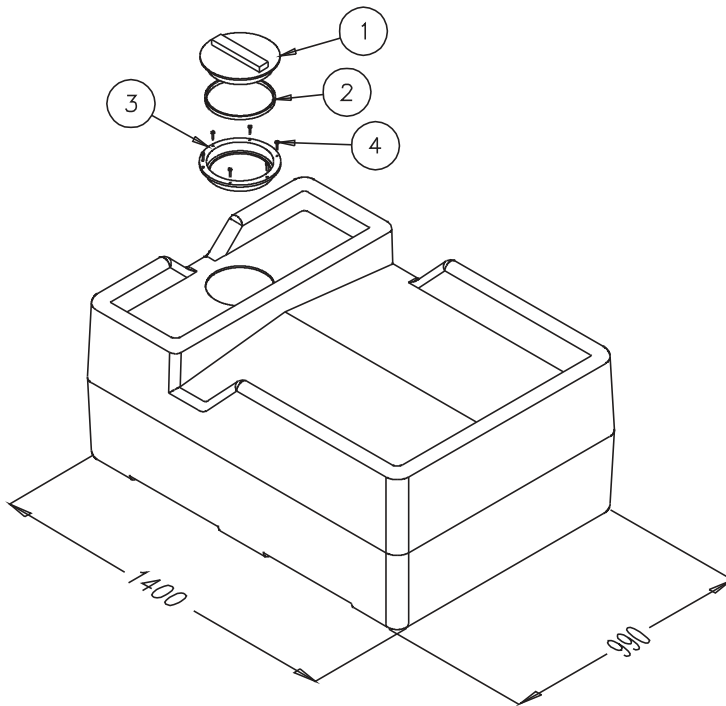

**OVERALL DIMENSIONS** 1420(L) X 1000(W) X 610(H)

ITEM	CODE	Description
1,2,3	ARLP250VSR	Ø255 Lid Assembly
4		Stainless Steel Screws

2

\*Rapid spray warranty requires fitting the Ball Baffle System to tanks larger than 6000 litres partially filled