

Active Liquid Tanks Specification Sheet



PTC00800FG

800 litre Free Standing Cartage Tank

Unit Specifications

Item	Description	Details
Tank	800 litre	UV stabilised polyethylene specially formulated for transport tanks. Complies with AS2070:1999 & AS4766:2006 compliant. Food grade with 10 year guarantee.
Lid	455mm	455mm diameter lid, rim & seal. 180° hinged tank lid supplied with fixing ring. Labyrinth breather valve. Gasket seal. Six point bayonet lock to provide perfect seal, UV stabilised polypropylene construction. Spill containment lip surrounds lid
Tank outlet	1 1/2" MBSP	Flanged polypropylene tank outlet fitting complete with nut & washer
Dimensions	PTC00800FG	1350mm(L) x 1200mm(W) x 690mm(H)
Dry weight		55kg
Baffles	Integral	Integral foam filled baffle
Colour		Faint green
Load Rating		1.3 Specific Gravity (SG)
Mounting	4 x 18 x 230mm Tank Mounting Pins	Mounts directly to any flat surface with galvanised steel mounting pins (optional)

1

Active Liquid Tanks Specification Sheet

Features

- Unconditional guarantee against rust
- Extraordinary impact resistance
- Impressive range of 'flex' to cope with chassis movement and twisting in tough operating conditions
- Calibrated for measurement of contents
- Mounts directly to any flat surface
- Spill containment lip surrounds lid
- Australian made for Australian conditions
- Optional tank colours available

For Use

- Potable (drinking water delivery)
- Dust suppression units
- Liquid fertiliser transport
- Water supply for spraying contractors
- Drillers mud
- Molasses transport

Dimensional Drawing – PTC00800FG

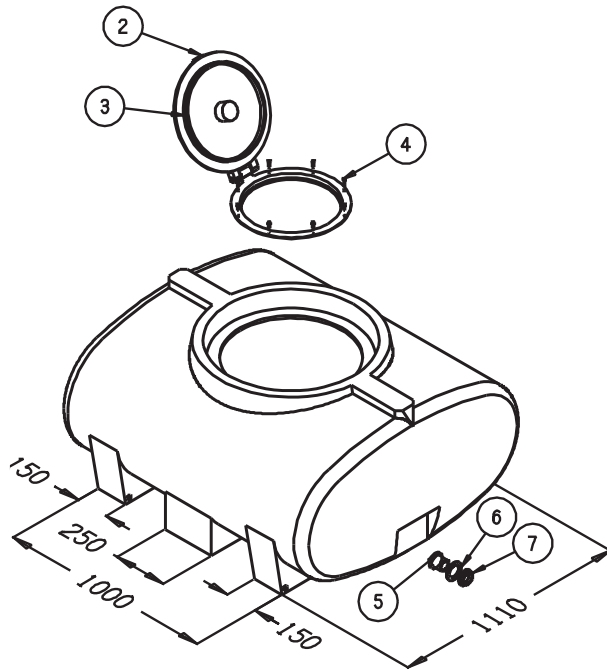

OVERALL DIMENSIONS 1350(L) X 1200(W) X 690(H)

ITEM	CODE	Description
2	ARLP450VSR	ø455 Lid, Rim & Seal Assy
3		ø455 Lid Seal Only
4		Stainless Steel Screws
5,6,7	ARFP038	1 1/2" MBSP Fitting - Poly

2

*Rapid spray warranty requires fitting the Ball Baffle System to tanks larger than 6000 litres partially filled