

Aqua-V Tanks Specification Sheet



STC01500LB

1500 litre Free Standing Cartage Tank

Unit Specifications

Item	Description	Details
Tank	1500 litre	UV stabilised polyethylene specially formulated for transport tanks. Complies with AS2070:1999 & AS4766:2006 compliant. Food grade with 5 year warranty.
Lid	455mm	455mm diameter lid, rim & seal. 180° hinged tank lid supplied with fixing ring. Labyrinth breather valve. Gasket seal. Six point bayonet lock to provide perfect seal. UV stabilised polypropylene construction. Spill containment lip surrounds lid
Tank outlet	1 1/2" MBSP	Flanged polypropylene tank outlet fitting complete with nut & washer
Dimensions	STC01500LB	1700mm(L) x 1320mm(W) x 1050mm(H)
Dry weight		85kg
Baffles	Integral	Foam filled integral baffle
Colour		Light blue
Load Rating		1.1 Specific Gravity (SG)
Mounting	(4) 24 x 260mm tank mounting pins	Mounts directly to any flat surface with galvanised steel mounting pins

1

Aqua-U Tanks Specification Sheet

Features

- Unconditional guarantee against rust
- Extraordinary impact resistance
- Impressive range of 'flex' to cope with chassis movement and twisting in tough operating conditions
- Specialised poly manufacturing process maximises strength with minimal weight resulting in greater payload opportunities
- Calibrated for measurement of contents
- Heavy duty tanks with load rating up to 1.1 specific gravity (SG)
- Australian made for Australian conditions
- 5 year warranty – buy with confidence
- In-built 'Flexi-Link® Technology' in each tank structure allows real flex to cope with those truck chassis twist and moves that happen during tough operating conditions
- 'Surefit' tank mounting pin kit and poly outlet supplied with tanks
- Extra fittings can be added almost anywhere
- Large tank opening for fast, easy filling
- Specifically moulded fittings to enable easy mounting to any flat surface....without the need for any frame

Applications

- Potable (drinking water delivery)
- Dust suppression units
- Liquid fertiliser transport
- Water supply for spraying contractors
- Drillers mud
- Molasses transport
- Agricultural chemical transport and mixing

What is Flexi-Link® Technology?

- A polymer formulation with unique molecular bonding technology that allows flex without loss of strength

Dimensional Drawing –STC01500LB

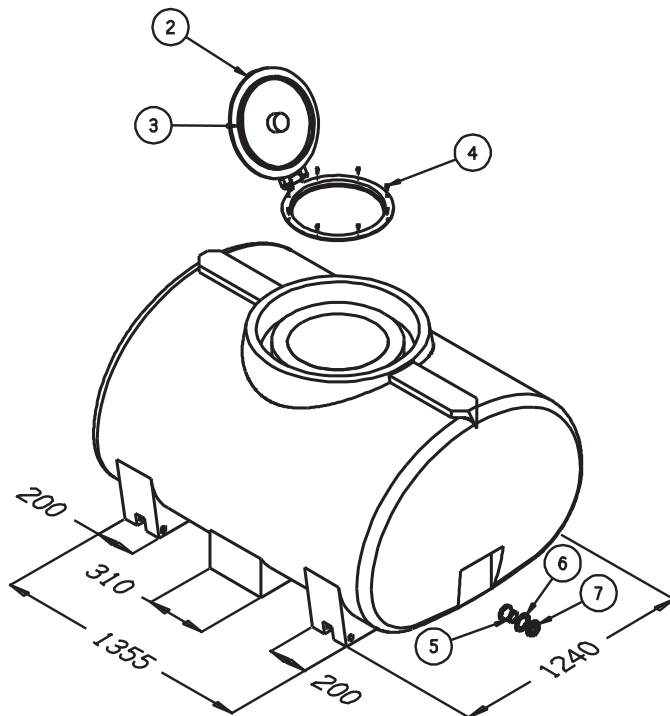

OVERALL DIMENSIONS 1700(L) X 1320(W) X 1050(H)

ITEM	CODE	Description
2	ARLP450VSR	ø455 Lid, Rim & Seal Assy
3		ø455 Lid Seal Only
4		Stainless Steel Screws
5,6,7	ARFP038	1 1/2" MBSP Fitting - Poly

*Rapid spray warranty requires fitting the Ball Baffle System to tanks larger than 6000 litres partially filled