



Spray Tanks



Warranty & Operator's Handbook

Contents

Introduction	2
Warnings	2
Warranty	3 & 4
Warranty Registration	5 & 6
Warning Information	7
Footing Detail Drawings	8
Risk Assessment	9
Customer Survey Form	10

READ YOUR OPERATOR'S HANDBOOK CAREFULLY BEFORE MOUNTING AND USING YOUR TANK. KEEP YOUR HANDBOOK IN A SAFE PLACE.

Introduction

Congratulations on your purchase of a Rapid Spray Free Standing Water Cartage Tank. Ideally suited to water cartage for contractors, farmers, earthmovers, landscapers, potable water carriers and many other applications.

Warnings

- ! 1. When mounting to any vehicle ensure that you have read the Vehicle Owner's Manual and that you comply with all the weight restrictions as specified by the vehicle manufacturer, as overloading can cause injury or death.
- ! 2. To ensure your own safety and that of your employees if applicable you must comply with all relevant environmental, work place health and safety legislation and codes of practice.
- ! 3. Ensure tank is firmly secured in an appropriate manner. Where applicable tank mounting may need to be designed / approved by an engineer.
- ! 4. Care should be taken at all times, particularly when operating on rough or steep terrain. Drivers should be aware of water surge at all times.
- ! 5. OH&S requirements for working at heights must be complied with as applicable.
- ! 6. Personal Protection Equipment must be worn if required.
- ! 7. Improper or careless use of this tank can cause serious injury or death. Minors should never be allowed to use this tank.
- ! 8. Tank is a confined space. Ensure compliance with OH&S requirements if entering tank.
- ! 9. You must be in good mental health to operate this tank and not be under the influence of alcohol or any drugs that could impair your vision, physical strength, dexterity, judgement, or other mental capacity.



RAPID SPRAY provides a quality tank and water cartage/spray system for the use of our clients.

To ensure continuous and quality use, we undertake this Warranty Agreement to enable trouble free and Quality Assured service of our tanks and spray systems.

Please read and understand all documents in the Warranty Pack adhered to your tank.

This pack contains:

1. Operators Handbook
2. Warranty Registration Form (with Serial #)
3. Mounting Plan and Directions
4. Frame Drawings
5. Documents to be Returned (including Pre-paid envelope)
6. Quality Assurance checklist
7. Load Restraint Guide (National Transport Association)

On purchasing a Rapid Spray tank or system, customers are requested to read all documents carefully and **ensure they understand** the operation system, ensure correct mounting and restraint to the specifications and drawings provided, **prior to use**.

Step 1. Take ALL documents and plans from plastic sleeve and read them

Step 2. Complete Warranty Registration Form and return to **Rapid Spray, PO BOX 3119 SINGLETON NSW 2330** (attach copy of receipt to Warranty Form) to initiate registration,

Step 3. Purchase or manufacture frame/mounting system in conjunction with Rapid Spray's design/plan

Step 4. Mount and secure tank in compliance with specifications as supplied by RAPID SPRAY

Step 5. Ensure any fittings from tank to motor/sprays or outlets are flexible and NOT rigid

In all cases WARRANTY WILL Include:

- Workmanship of tank (manufacture)
- Quality of raw materials and fittings
- Integrity and workmanship of frame/skid – if purchased from Rapid Spray
- Guarantee on NEW Tank for a pro-rata period of 5 years (for original purchaser)
- Mounting instructions are adhered to and proof of purchase is provided

TO AVOID DOUBT – Warranty does not cover the following:

- Tank mishandling, misuse, or faults caused by failure to follow mounting advice or routine maintenance.
- Unauthorised alterations or changes to tanks (including welding, cutting, or mounting)
- Damage from use of rigid/fixed outlets to pumps or other fittings
- Damage from wear or tear
- Incorrect placing and securing of pumps or tanks
- Freight or costs associated with repairs associated with any of the above
- Costs associated with dismantling, installation or re-installation of the tank or frame

CLAIMS PROCEDURE:**WHAT TO DO IF YOUR PRODUCT BREAKS DOWN?**

- CONTACT RAPID SPRAY ON **1800 011 000** and follow our simple steps to make a claim under Warranty.

FOLLOW OUR SIMPLE CLAIMS PROCEDURE.

- Please have your invoice #, Date of purchase, and Co. Purchased from, prior to calling,
- Take digital photo of affected area/mount/tank, etc and email to ***store@rapidspray.net***
- Our Warranty personnel will verify your warranty number and advise you of action to be taken.
- You will be notified if your product needs to be returned and/or the action to be undertaken.
- Our aim is to have your unit returned As Soon As Possible, depending on the seriousness of your problem
- Remember, it is at the discretion of Rapid Spray to repair, replace or refund the unit,
- If any unit (pump, motor or tank) is found to have been mishandled, inappropriately used, mounted or secured; the costs associated will be incurred by the client.

If you have any questions regarding this policy, please call our Sales staff or Warranty department on 1800 011 000 Monday to Friday 8-00am to 4-00pm.

RAPID SPRAY – Singleton

RAPID SPRAY WARRANTY AGREEMENT

Form A

Rapid Spray Copy

TANK INSTALLATION/MOUNTING

ALL TANKS MUST BE MOUNTED IN ACCORDANCE OF RAPID SPRAY'S DETAILS, PLANS, DRAWINGS and INSTRUCTIONS

Please read and complete ALL sections of this form in CAPITAL letters. Mark appropriate boxes with a tick ✓

▶ INSTRUCTIONS

- This is a general warranty for clients who purchase a Rapid Spray tank or frame.
- Warranty will only apply to original purchaser
- Warranty Registration is effective if completed and returned within 21 days of original purchase

▶ 1. NAME and PHONE # OF PURCHASER

Please use full name or name of company

e.g. Inc for companies, or full first and last name for individuals

▶ 2. ADDRESS

Please add full address NOT P.O. BOX

.....Ph:
..... Fax:

▶ 3. PLACE OF PURCHASE

BUSINESS:.....
ADDRESS:.....
TELEPHONE:..... SALESPERSON:..... DATE: / /

▶ 4. TANK OR PRODUCT PURCHASED

TANK/PRODUCT DESCRIPTION: PRODUCT CODE:.....
.....SERIAL NO:

▶ 6. AGREEMENT

I have read and understand the plans, details and instructions provided by Rapid Spray on MOUNTING my tank, SECURING my tank, COMPLIANCE with RTA (Load Restraint Guidelines) and general vehicle operation. I agree to MOUNT and SECURE my tank with the products supplied and in accordance of Rapid Spray ENGINEER's DRAWINGS (supplied).

NB. ALL FITTINGS and HOSES FROM TANK OUTLET TO PUMPS Etc. ARE TO BE FLEXIBLE AND NOT RIGID!

I also understand that on tanks in excess of 4800 Litres, it is recommended that BAFFLE BALLS be used to regulate or dampen the effects of surge; and it is essential that BAFFLE BALLS are an integral part of the safety system in 10,000, and 13,000 litre tanks.

I acknowledge that if I fail to comply with the MOUNTING, SECURING and SUPPORTING of my tank; I will VOID the explicit WARRANTY, and could possibly incur the cost of freight to RAPID SPRAY – SINGLETON for the repair of my tank; OR at the least, the cost of a nominated and qualified PLASTIC WELDER to repair the damage.

▶ 7. SIGNATURE

Signature Name:
Position

DISCLAIMER: If you don't want us to keep you informed of new products please tick this box

Office Use ONLY

On completion of this agreement, please return to RAPID SPRAY, 35 ENTERPRISE CRESCENT SINGLETON. N.S.W. 2330 or go to www.rapidspray.net to register your Warranty Document.

RAPID SPRAY WARRANTY AGREEMENT

Form B

Customer Copy

TANK INSTALLATION/MOUNTING

ALL TANKS MUST BE MOUNTED IN ACCORDANCE OF RAPID SPRAY'S DETAILS, PLANS, DRAWINGS and INSTRUCTIONS

Please read and complete ALL sections of this form in CAPITAL letters. Mark appropriate boxes with a tick ✓

▶ INSTRUCTIONS

- This is a general warranty for clients who purchase a Rapid Spray tank or frame.
- Warranty will only apply to original purchaser
- Warranty Registration is effective if completed and returned within 21 days of original purchase

▶ 1. NAME and PHONE # OF PURCHASER

Please use full name or name of company

e.g. Inc for companies, or full first and last name for individuals

▶ 2. ADDRESS

Please add full address NOT P.O. BOX

..... Ph:

..... Fax:

▶ 3. PLACE OF PURCHASE

BUSINESS:.....

ADDRESS:.....

TELEPHONE:..... SALESPERSON:..... DATE: / /

▶ 4. TANK OR PRODUCT PURCHASED

TANK/PRODUCT DESCRIPTION: PRODUCT CODE:.....

..... SERIAL NO:

▶ 6. AGREEMENT

I have read and understand the plans, details and instructions provided by Rapid Spray on MOUNTING my tank, SECURING my tank, COMPLIANCE with RTA (Load Restraint Guidelines) and general vehicle operation. I agree to MOUNT and SECURE my tank with the products supplied and in accordance of Rapid Spray ENGINEER's DRAWINGS (supplied).

NB. ALL FITTINGS and HOSES FROM TANK OUTLET TO PUMPS Etc. ARE TO BE FLEXIBLE AND NOT RIGID!

I also understand that on tanks in excess of 4800 Litres, it is recommended that BAFFLE BALLS be used to regulate or dampen the effects of surge; and it is essential that BAFFLE BALLS are an integral part of the safety system in 10,000, and 13,000 litre tanks.

I acknowledge that if I fail to comply with the MOUNTING, SECURING and SUPPORTING of my tank; I will VOID the explicit WARRANTY, and could possibly incur the cost of freight to RAPID SPRAY – SINGLETON for the repair of my tank; OR at the least, the cost of a nominated and qualified PLASTIC WELDER to repair the damage.

▶ 7. SIGNATURE

Signature Name:

Position

DISCLAIMER: If you don't want us to keep you informed of new products please tick this box

Office Use ONLY

On completion of this agreement, please return to RAPID SPRAY, 35 ENTERPRISE CRESCENT SINGLETON. N.S.W. 2330 or go to www.rapidspray.net to register your Warranty Document.

Warning Notices

Copy of stickers attached to tank are shown below. Please ensure that these instructions are followed.



On the following page is a recommended frame design for mounting our tanks.

WARRANTY IS CONDITIONAL ON TANK BEING CORRECTLY MOUNTED.

Liquid Surge

Rapid Spray strongly recommends the use of the Rapid Ball Baffle system to control liquid surge when in transit. Please call 1800 011 000 for details.

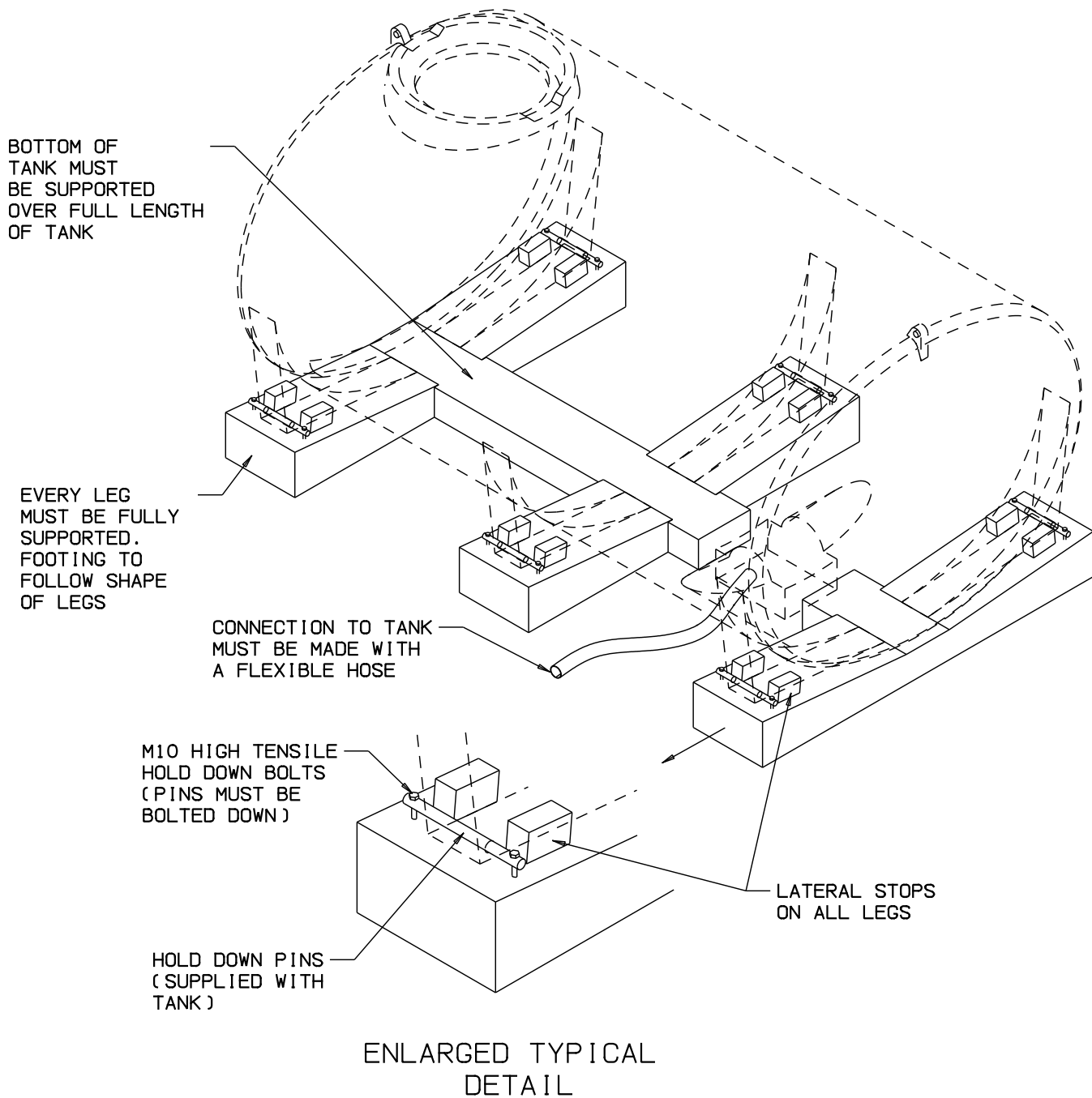

FOOTING DETAILS FOR TANKS WITH A SUMP

RAPID SPRAY PRODUCT INFORMATION RISK ASSESSMENT SHEET**ITEM 2 SPRAY TANKS-NON WATER****Codes:-ST0000's**

Task	Hazards	Risk	Control Measures
1. Ensure tank mounted correctly on vehicle and do not overload vehicle, partially fill the tank with water & test the tank or pumping system, if necessary, before use.	Load not secured; overload vehicle; manual handling; slips, trips or falls; fingers jammed; overhead powerlines-electricity; leaks; tank is a confined space.	Med	Read/follow decals on the tank; follow safe manual handling techniques:-don't lift on your own if > 20kg, bend knees & keep back straight; keep fingers clear; keep tank at least 8m away from overhead powerlines; keep water away from electrical sources; make sure tank mounted securely to Comply with relevant codes of practice and transport authority requirements; don't exceed vehicle load limit; follow state legislation & AS 2865: 2001 Confined Space; trailer chassis mount frame if used on roads
2. Check weather and ground conditions & select the appropriate PPE to suit the chemicals to be used-if applicable.	Manual handling; slips, trips or falls; ground instability.	Low	Put on PPE, as required from the Material Safety Data Sheet- coveralls, gloves, safety footwear, glasses & respirator; follow safe manual handling techniques as above; drive cautiously to suit conditions.
3. Mix chemicals & fill tanks with chemicals and or water. Check that transport vehicle is safe before use, i.e. where applicable:- wheel nuts, tyre pressure, bearings, tow hitch, has been serviced, etc.	As above for 1 & 2; spray drift, chemical spillage, emission of vapours or flammability; weather; untrained visitors	Med	As above 1 & 2; user trained in the state's chemical mixing & administration course eg Chem Cert; follow the relevant Environment Protection Authority requirements; fire extinguisher present; keep visitors away from the job unless wearing full PPE.
4. Use tank from a vehicle-take into account the sway of the water & fluid in the tank when driving.	As above; loss of load; work in heat & cold; noise; exceed load limit of vehicle; strap breakage; hose entanglement; exhaust fumes; terrain & slopes	High	As above 1 & 2; wear clothes to suit heat & cold; wear hearing protection if pump noise > 85 dBA; follow manufacturer's safe operation instructions for the vehicle & the pump/spray unit; don't overload-water weighs 1kg per 1 litre; secure load to vehicle; hose tidy.
5. Clean up, maintenance & storage	As above.	Low	As above; continue to wear PPE for clean up; store tank in a dry, well ventilated area.



To help us to help you further, please complete and return the following with your warranty registration.

Alternatively, you can complete this survey online at www.rapidspray.net.

• Purchaser's Age

- Up to 25
- 25 - 40
- 41 - 55
- Over 55

• Principle Usage

- Commercial Farm
- Hobby Farm
- Industrial
- Other.....
- Town Council
- Hire Company
- Home

• What influenced you to purchase a Rapid Spray product?

- Catalogue received
- Newspaper Advertisement
- Magazine Advertisement
- Dealer Recommendation
- Friend's Recommendation
- Better features than other sprayers
- Quality and Reliability
- Price
- Past Experience with Rapid Spray Products

• What other Rapid Spray products do you use?

- Spray Tanks
- Cartage Tanks
- Diesel Tanks
- Inter Knapsacks / Compression Sprayers
- Boom Sprayers
- Bertolini Pumps and Controllers
- Fire Fighters
- Other.....

Any Comments?



35 Enterprise Crescent, Maison Dieu Industrial Estate, SINGLETON
PO Box 3119, SINGLETON NSW 2330
Ph (02) 65 788 100
Fax (02) 65 712 951
www.rapidspray.net