

FIRESOOUT

360L / 600L ULTRA COMPACT FIRE FIGHTER

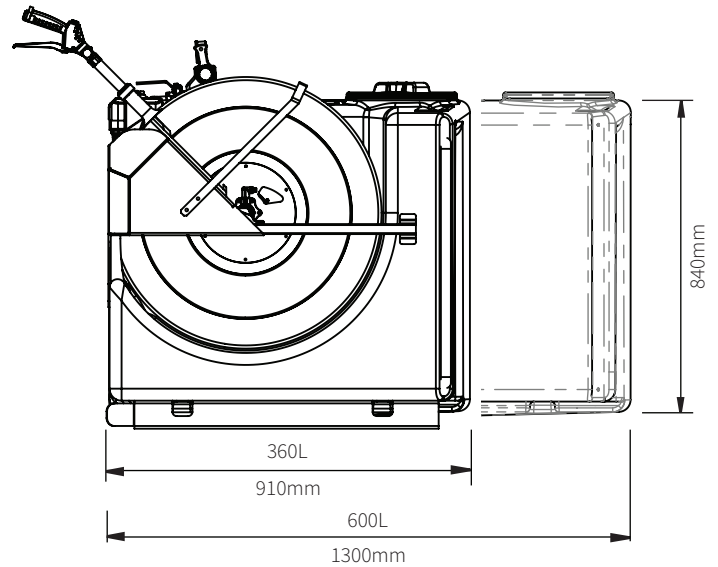

360L & 600L FireScout

SPRAYER SPECIFICATIONS

Item	Description	Details
Tank	360L 600L	UV stabilised chemical resistant polyethylene tank with integral sump. 15 year guarantee. AS2070:1999 compliant
Mounting	Frame	Galvanised forklift pockets and moulded lifting and tiedown handles
Pump	FireChief Petrol	490L/min 100 psi max, 2" fire pump with 5 year warranty
	FireChief Petrol	450L/min 100 psi max, 2" fire pump with 5 year warranty
Motor	Honda GX200	4 stroke, overhead valve, single cylinder. 4.1kW @ 3600rpm. 3 year warranty
	Yanmar L48	Diesel recoil start, single cylinder. 3.5kw @ 3600 rpm. 1 year warranty
Hose Reel	36 metre manual	UV stabilised poly hose reel on galvanised steel frame, full flow ball bearing swivel, brass and stainless steel components, reel lock, rotating handle
Fire Hose	36m x 19mm fire hose	36 metres AS 1221 rated, 19mm fire hose with adjustable nozzle fitted to hose wrap
Lid	250mm (2)	Threaded lid assembly with fixed labyrinth breather, UV stabilised
Drain	1 1/2"	Quick drain with camlock cap
Bottom Fill Kit	6 metre	with Camlock fittings and foot strainer for filling from creeks and dams

Tank Capacity	Length	Width	Height
360L	910mm	1100mm	840mm
600L	1300mm	1100mm	840mm