

SPOT RANGER

12 VOLT SPOT SPRAYERS



SVR0060L0083 - 60L



SVR0095L0083 - 95L



SVRT0095L0083ZB2 - 95L
with trailer & 2m boom

60L & 95L SPOT RANGER SPRAYERS

UNIT SPECIFICATIONS

Item	Description	Details
Tank	60L / 95L	UV stabilised chemical resistant polyethylene tank, lance & hose holder. 15 year warranty. Made in Australia
Pump	12 Volt Delavan	Delavan 3 chamber positive displacement diaphragm pump, 8.3L/min 400kpa (60psi), demand switch, viton valves, santoprene diaphragm
Pressure regulator	Arag	Threaded pressure regulator with polypropylene body reinforced with fibreglass, EPDM gaskets internal ports in Dlerin & stainless steel AISI 303
Filter	Suction filter	Suction foot filter with 10mm hose tail
Filter	Basket Filter	100mm Ø poly basket filter
Pressure gauge		Glycerin filled 0-200psi gauge with 1/8" bottom port
Spray gun	Powerjet	Powerjet spray gun with stainless steel ball and seat housing. Max pressure 20bar 300psi, adjustable spray nozzle
Spray hose	10mm ID	6 metres of 10mm chemical spray hose
Lid		120mm screw lid with breather
Power source	12 volt	3.6m 12 volt electrical leads with fuse, switch, alligator clips and cigarette lighter adaptor
Mounting	Inserts	4 x M8 brass inserts on bottom of tank
Drain	Bung	3/4" drain bung and seal



SPOT RANGER

PRODUCT SPECIFICATION SHEET



SPECIFICATIONS CONT.

TANK SPECIFICATIONS

Code	Tank Capacity	Length	Width	Height	Weight
SVR0060L0083	60 Litres	1019mm	480mm	380mm	10kg
SVR0095L0083	95 Litres	1019mm	480mm	490mm	11kg

FEATURES

- Easy access lid with strainer
- Graduations for easy measurement of contents
- Provision for the straps - supplied
- Access in tank to accommodate rack rail on quads
- Anti-spill lid surround to prevent chemical splashes
- Spare outlet tap for boom attachment
- Spray lance holding clips
- Secure brass regulator mount
- Easy carry moulded handle grips
- Drain plug for easy cleaning

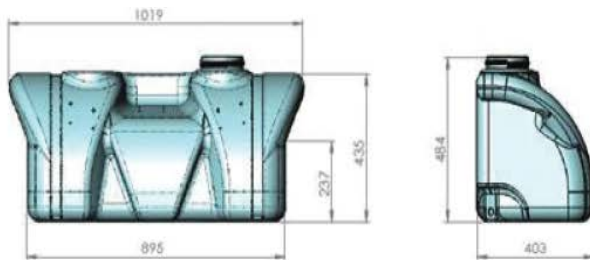

Dimensions of 95 Litre

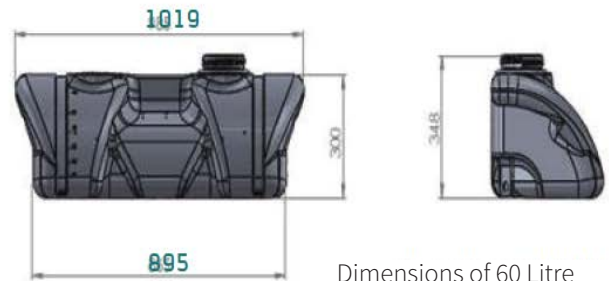

Dimensions of 60 Litre

PUMP SPECIFICATIONS

Pump Model	Motor	Liquid Temp	Priming Capabilities	Max Pressure	Housing	Valves	Diaphragm	Fasteners	Weight
Delavan APD0083Q	12 VDC permanent magnet totally enclosed, fin cooled	60°C	4m	60psi	Polypropylene	Viton	Santoprene	Stainless steel & zinc plated	2.7kg

PARTS BREAKDOWN - DELAVAN PUMP - APD0083Q10

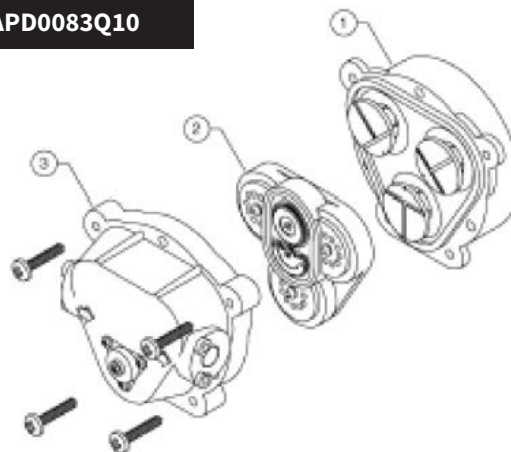

PARTS LIST

Item no.	Code	Qty	Description
1	CDPLHA78607E77	1	Lower housing 7801 Demand
1	CDPLHA78637F77	1	Lower housing 7802 Demand
2	CDPVHA78637F77	1	Valve assembly 7801/7802 Demand
3	CDPUHA78637F77	1	Upper housing 7801/7802 Demand

PUMP PERFORMANCE

PSI	LPM	AMPS
10	7.6	2.8
20	6.4	3.7
30	6.0	4.2
40	5.9	4.7
50	4.7	5.2
60	4.0	5.7

SPOT RANGER

PRODUCT SPECIFICATION SHEET



OPTIONS & ACCESSORIES

ZERO-TURN TRAILER KIT

ATK06095TZ

- Long drawbar for extra sharp turning with zero-turn mowers
- Powdercoated RHS frame
- Mounts a variety of boom kits



ATV BOOM MOUNTING KIT

ATK055095A

- Easy ATV mounting system with 90° angle design for versatility
- Powder coated steel construction guarantees superior load bearing



SILVER SELECTION BOOMS

ABS020 / ABS030 / ABS040

- Breakaway & fold-up arms on ABS030/ABS040 booms
- Sturdy powdercoated steel frame
- Non-drip check valve nozzle bodies
- 1000mm nozzle spacings
- 140° deflector nozzles
- Complete with adaptor plate to suit ATV mounting

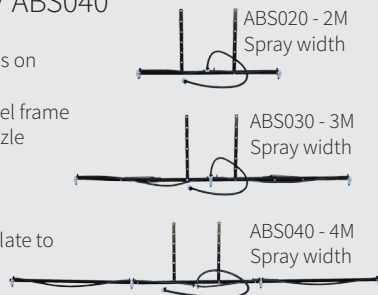

VERSATILE BOOM KIT

ABVL040

- 1.2 metre compact boom
- Sprays 4m swath width
- Requires pump min flow - 7.5L/min
- Taps for 7-way nozzle control
- Versatility of spraying options
- Non-drip ball check filters



GEOLAST DIAPHRGM

CDP53LHA002

- Geolast diaphragm available for use with diesel based sprays

