



ULTIMATE FIRE RANGER UNITS

OPERATORS HANDBOOK



400L - 2,500L CAPACITIES



CONTENTS

Statement of Suitability for Rapid Spray Diesel Tanks

01	Introduction
02	Warnings
03	Product Risk Assessment
04	Operating Instructions
04	Before Use
04	Operation
05	Decontamination & Maintenance
09	Parts Breakdown
09	Fire Ranger 400 - 2,500L Units
08	Poly Fire Fighting Hose Reel
09	Bottom Fill Kit
	Contents
	Warnings
	Operation
10	Aussie Fire Chief Pump
12	Warranty Registration

INTRODUCTION

Congratulations on your purchase of a Rapid Spray Fire Fighting Unit which is complete and ready to slip onto a ute, truck or trailer for immediate action when you need it most.



WARNINGS

1. When mounting to any vehicle. Ensure that you have read the Vehicle Owner's Manual and that you comply with all weight restrictions specified by the vehicle manufacturer as overloading can cause injury or death.
2. To ensure your own safety and that of your employees if applicable you must comply with all relevant environmental, work place health and safety legislation and codes of practice. In particular be aware of Rural Fire Service guidelines for safety when fighting fires or backburning.
3. Select and wear appropriate Personal Protection Equipment in accordance with your own safe work practices.
4. Improper or careless use of this unit can cause serious injury or death. Minors should never be allowed to use this unit. This unit should not be used when bystanders or animals are in the area. This unit should never be used while children are in the area.
5. Never leave the unit unattended without turning off the engine and relieving the line pressure.
6. You must be in good mental health to operate this unit and not be under the influence of alcohol or any drugs that could impair your vision, physical strength, dexterity, judgement, or other mental capacity.
7. All operators must be trained in safe use of this unit.

PRODUCT RISK ASSESSMENT

TASK	HAZARDS	RISK	CONTROL MEASURES
Partially fill the tank with water, start the motor and test the fire unit	Manual handling; slips, trips or falls; petrol; fumes; fingers jammed	Medium	Concentrate on task; follow safe manual handling techniques; don't lift on your own if >20kg, bend knees and keep back straight; keep fingers clear; keep unit at least 8m away from overhead powerlines; fire extinguisher nearby; follow warning stickers on tank; wear PPE for petrol and fumes – mask and gloves
Check weather conditions and select the appropriate PPE to suit the chemicals to be used (if applicable)	Manual handling; slips; trips or falls	Low	Put on PPE as per the chemical requirements in the Material Safety Data Sheet – coveralls, gloves, safety footwear, glasses and respirator; follow safe manual handling techniques: don't life on your own if > 20kg, bend knees and keep back straight
Mix chemicals (if applicable) and fill fire fighting unit	As above; spray drift, chemical spillage, emission or vapours or flammability; weather; untrained visitors	Medium	As above; user trained in the state's chemical mixing administration course eg: Chem Cert; follow the relevant Environmental Protection Authority requirements; fire extinguisher present; keep visitors away from the job unless wearing full PPE
Use fire fighter unit	As above; loss of load; heat and cold; noise; exceed load; limit of vehicle; hose entanglement; exhaust fumes; terrain and slopes; run over by unit	High	As above; wear clothes to suit heat and cold; wear hearing protection if noise >85dba; follow the manufacturer's safe operation instructions for the vehicle and the spray unit; don't overload – water weighs 1kg for every 1 litre; secure load to vehicle; keep hose tidy; put brakes on
Clean up, maintenance & storage	As above	Low	As above; continue to wear PPE for clean up; store unit in a dry, well ventilated area

OPERATING INSTRUCTIONS

BEFORE USE

1. Check all hoses, connections and hose clamps to ensure that the unit has been delivered to you without transportation loss or damage.
2. Before attempting any fire fighting with your new unit, operate it to familiarise yourself with its features and capabilities and to ensure that your unit has arrived in a safe working condition. Please contact your dealer immediately should anything appear to have been damaged.
3. Load the unit onto the back of a vehicle and fasten the unit securely to the vehicle by strapping or bolting it down. Ensure that the straps do not interfere with any hoses or connections. Do not place the straps over the pump or engine. Keep hoses and straps away from hot engine, exhaust and exhaust fumes.
4. Prepare the engine for use as per the engine manual supplied with your unit. Ensure that the correct quantity and type of oil is used when filling the engine.

OPERATION

- Fill tank from appropriate water source. For bottom filling see page 5 for instructions. Open ball valve on suction hose at bottom of tank. Start motor and allow to warm up. Bypass valve is fitted to top of pump and should be adjusted to allow bypass for warm up period.
- Unlock hose reel to allow hose to be pulled out. When using fire fighter adjust nozzle to desired spray pattern.
- Increase engine speed and adjust bypass to achieve desired flow rates. When job is finished turn engine off, rewind hose onto reel and lock reel to prevent unwinding. Close ball valve on suction hose.
- Please note this unit is designed for fire fighting and washdown or tree watering use and not for chemical spraying. Please consult the manufacturer for further information.

DECONTAMINATION & MAINTENANCE

1. After use the unit must be thoroughly decontaminated, inside and out, including pump, hoses and hand lance to prevent damage to the unit from corrosion or abrasion. As a guide follow the decontamination procedures below:
 - a. After use, the tank, pump, hand lance/nozzle and (if required) hose should be flushed by running it with clean water plus a recommended cleaning fluid.
2. When storing the unit, ensure that it is clean and dry and store in a well ventilated place.
3. If operating in areas where freezing occurs we recommend leaving anti-freeze in the pump, regulator/bypass valve and handgun/nozzle while not being used to prevent possibility of frost damage.



PARTS BREAKDOWN

FIRE RANGER 400 - 2,500L UNITS

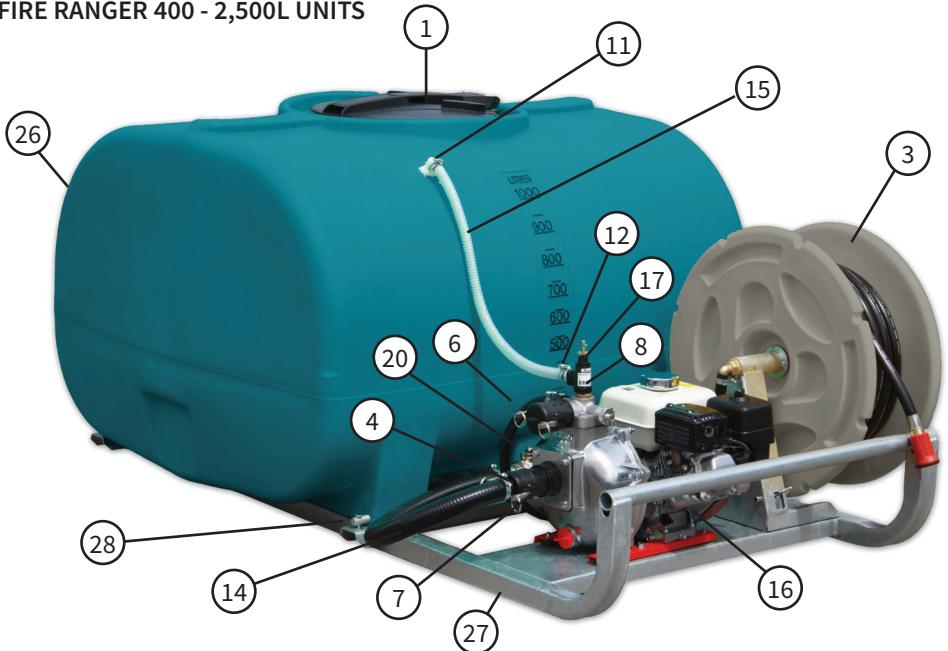

BOTTOM FILL KIT - AFK006

Bottom fill kit for fire fighting units
Includes: 6m hose, camlock fittings and foot strainer



25 MOTOR COVER - AMHMCYE

Motor cover to suit Honda motors

RAPID BALL BAFFLE - ARB195 / ARB355

All Fire Ranger fire units are fitted standard with the Rapid Ball Baffle system.

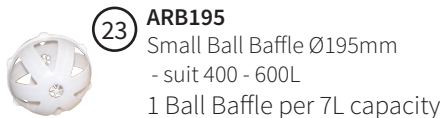

23 ARB195

Small Ball Baffle Ø195mm
- suit 400 - 600L
1 Ball Baffle per 7L capacity



24 ARB355

Small Ball Baffle Ø355mm
- suit 800 - 2,500L
1 Ball Baffle per 40L capacity

GUARANTEED
FLUID STABILITY
MEANS SAFER
OPERATION

Parts List

#	Parts No.	Description
1	ARLP250VSR	Ø250mm screw lid completed with rim & deal - suits 400 - 600L
	ARLP450VSR	Ø450mm lid, rim and seal assembly - suits 800 - 2,500L
2	CAP356660020NB	Ø450mm lid seal only (not shown)
3	AFHW10B036M19	36m fire fighting poly hose reel & adjustable nozzle
4	CFFCP040C	1 ½" camlock F w/ 38mm hose tail
5	CFFCP040A	1 ½" camlock adaptor M/F thread
6	CFFCP040H	1 ½" camlock cap to suit M adapter
7	CAP2452067	2" female to 1 1/2" male reducer
8	CFBR25M20F	1 - ¾" brass reducing bush for F/F bypass
9	ATPFFB40	40mm foot strainer for F/F quick fill
10	CFGE40M40F	40mm M & F 90° gal elbow male
11	CFNE20M20B	¾" x 20mm barb poly elbow
12	CFNS20M20B	¾" x 20mm barb straight
13	CFZS40M40B	28mm hose tail, combination nipple zinc
14	CUUB 38mm	38mm black suction hose
15	CUUC 19mm	19mm clear suction hose
16	APF4900Z	Aussie Fire Chief 2 inch pump w/ GX160 Honda motor
17	ATRV150PT20	Pressure relief valve ¾" nylon
18	CFYS25N20TC	1 - ¾" nut & tail
19	ARFB038R	1 ½" brass tank fitting
20	CFVBB040F040F	40mm 1 ½" lever ball valve
21	CFVBB040M040FBV19M	40mm 1 1/2" ball valve M/F suit PFUS0400LZ (not shown)
22	CFNW20F	¾" spinweld flush (not shown)
23	ARB195	Rapid Ball Baffle 195mm to suit 400-600 litre
24	ARB355	Rapid Ball Baffle 355mm to suit 800-2500 litre
25	AMHMCYE	Motor cover to suit Honda motors
26	PTC00400FG	400 litre free standing tank
	PTSS00400FG	400 litre cylindrical tank to suit PFUS0400LZ Short
	PTC00600FG	600 litre free standing tank
	PTC00800FG	800 litre free standing tank
	PTC001000FG	1000 litre free standing tank
	PTC01200FG	1200 litre free standing tank
	PTC01500FG	1500 litre free standing tank
	PTC02000FG	2000 litre free standing tank
	PTC02500FG	2500 litre free standing tank
27	ASFF00400	Steel frame to suit 400-600 litre
	ASFF00400A	Steel frame to suit 400 PFUS0400LZ short
	ASFF00800	Steel frame to suit 800 litre
	ASFF01200	Steel frame to suit 1200-1500 litre
	ASFF02000	Steel frame to suit 2000-2500 litre
28	ARP001	18x200mm mounting pin x 4 suit 400-600 litre
	ARP002	18x230mm mounting pin x 4 suit 800-1000 litre
	ARP004	24x260mm mounting pin x 4 suit 1200-1500 litre
	ARP005	24x330mm mounting pin x 4 suit 2000-2500 litre

POLY FIRE FIGHTING HOSE REEL - AFHW10B036M19

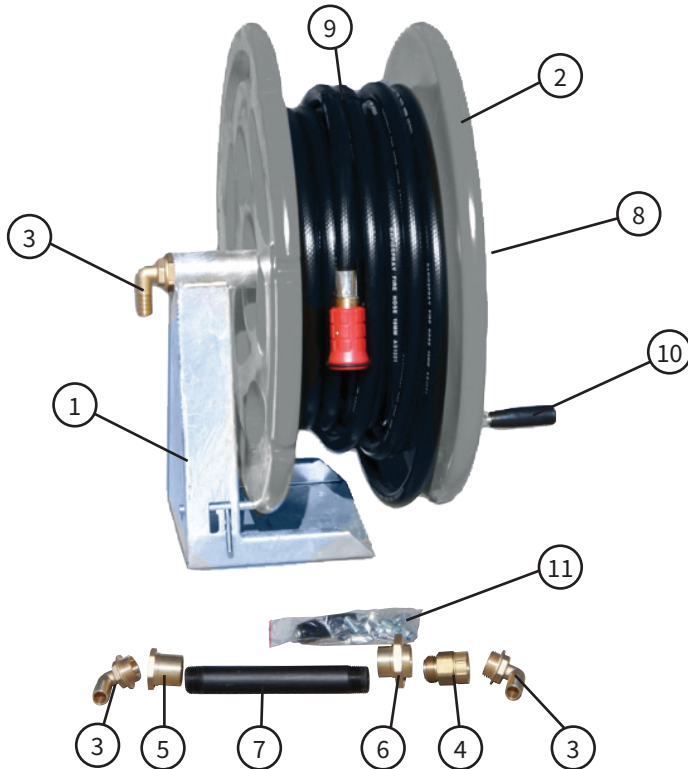

Parts List

#	Parts No.	Description
1	ASR10B	Base mount frame for fire hose reel
2	AMATH100MYE	Bare hose reel
3	CFBE25M20B	1" BSP to 20mm tail brass elbow
4	CFSPB25M25F	1" BSPM to 1" BSPF brass swivel
5	CFBL25F1	Back end brass nut
6	CFBL25F2	Swivel end brass nut for hose reel
7	CFPPT25M220	25-220mm screw pipe piece poly
8	CHJCH01X100X30	Spring for FF hose reel
9	CUF14519MMX36N	36m length x 19mm fire hose with nozzle
10	CHHRB10M080	Rotating handle M10 x 80 for hose reels
11	Mounting Pack	4 x M10 Nyloc nut zinc, 4 x M10 3/8 flat washer zinc, 4 x M10 x 30 4-6 zinc set screw
12	CNAFP20F	Poly 3/4" adjustable fire fighting nozzle - to be supplied with 3/4" x 19mm hose tail

BOTTOM FILL KIT

CONTENTS

- 6m x 38mm suction hose
- Camlock fittings
- Foot strainer

Aussie Pumps are designed for sucking water directly out of dams or water sources. The bottom fill kit is a quick, environmentally safe way of sucking up water to fill the water tank.

WARNINGS

Do not change hoses while engine and pump are operating. Observe all precautions listed in Fire Fighter Operator Manual. Be aware of hazards working near water sources particularly dams and rivers – slipping, falling, drowning and use safe work practices at all times.

OPERATION / PROCEDURE

1. Turn off engine.



2. Remove camlock cap from large outlet on pump - refer to visual.

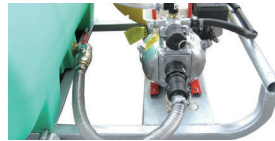

3. Detach the suction hose from pump and attach to top outlet - refer to visual



4. Attach suction hose from bottom fill kit to suction point of pump - refer to visual.



5. Place foot strainer and hose into water source - ensure the strainer is in clean water free of sludge or debris.

6. Open ball valve at bottom of tank.

7. Start engine and operate until tank is full.

8. When tank is full engine off, close valve at bottom of tank and reverse steps 4 to 2 and unit is ready to use.

NOTE: Rapid Spray recommend removing / opening tank lid while filling tank.

AUSSIE FIRE CHIEF - QP205SE

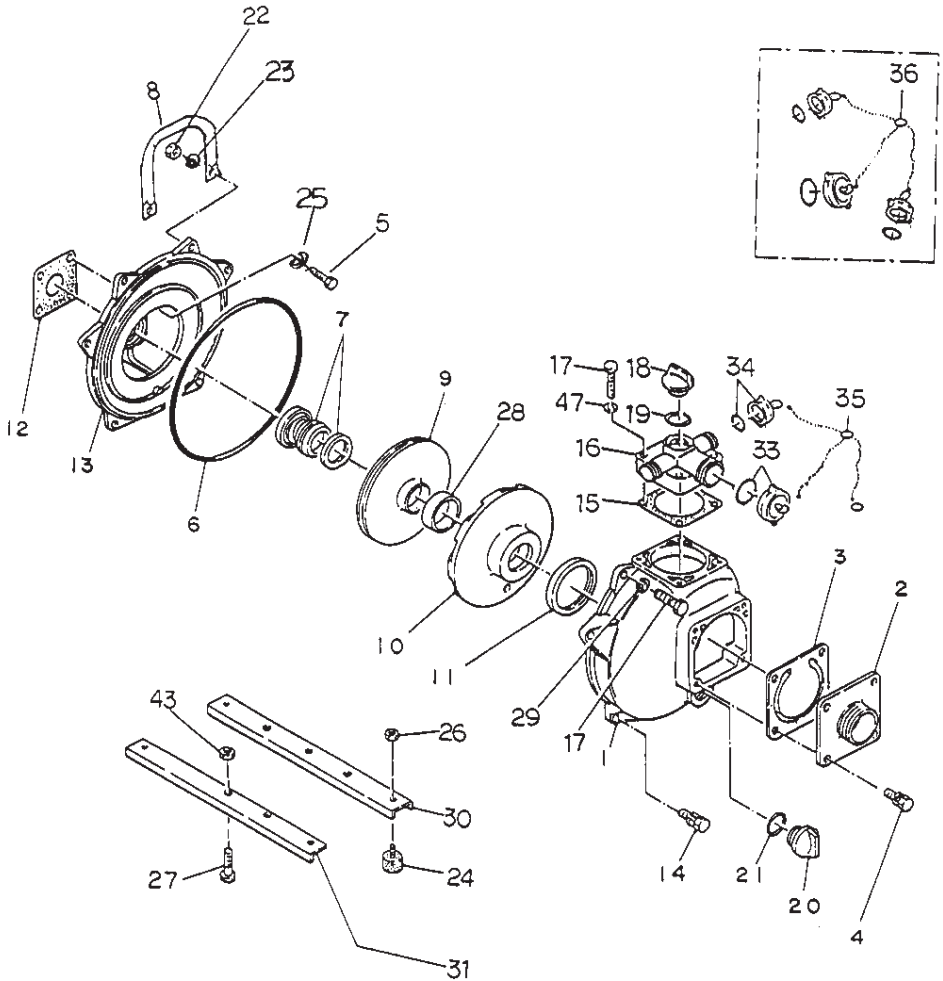

Parts List			
#	Parts No.	Description	Qty
1	Q4364-100010 Q7304-100010	Casing Casing with logo	1
2	Q1803-100160	2" suction cover	1
2	Q4725-060160-0011	1.5" suction cover	1
2	Q4904-000160	2.5" suction cover	1
3	Q1378-350350	Check valve	1
4	Q018108-0825	Bolt set with spring washer	4
5	Q019115-0525	Bolt	4
6	Q048935-2550	O-ring (casing)	1
7a	Q080311-2320	Mechanical seal	1
7b	Q080311-2320V	Viton mechanical seal	1
8	Q1883-207010-0003	Handle	1
9a	Q1806-060031	Impeller ¾" P shaft (37mm boss)	1
9b	Q1803-060031	Impeller w shaft (18mm boss)	1
9c	Q1814-060030	Impeller ¾" P shaft (GX200E only)	1
9d	Q2242-060030	Impeller for Robin DY23 & DY27 only	1
10	Q1803-100130	Volute casing	1
11	Q1378-330620	Volute casing packing	1
12	Q1211-390610	Casing cover packing	1
13	Q9358-100020	Mounting flange - P type	1
13	Q1378-100020	Mounting flange - W type	1
14	Q018105-0825	Bolt set with spring washer	1
15	Q1803-330360	Delivery cover packing	1
16	Q1814-100090	Delivery cover packing (3 way outlet)	1
16	Q1803-000090	Delivery elbow 2"	1
16	Q4904-000090	Delivery elbow 2.5"	1
17	Q010505-0845	Bolt	6
18	Q063121-1100ASS	Flooding cap with o-ring	1
19	Q048035-0300	O-ring (flooding cap)	1
20	Q063121-1100ASS	Flooding cap with o-ring	1
21	Q048035-0300	O-ring (drain cap)	1
22	Q020915-0080	Flange nut	2
23	Q040145-0080	Washer	2
24, 26, 27, 30, 31, 43	QSKIDSET	Skid set	1
28	Q1803-521220	Liner ring	1
29	Q045125-0080	Spring washer	2
36	QCAPS&CHAINS	Caps & chains	1
47	Q045125-0080	Spring washer	4

WARRANTY

The following warranty is the only warranty applicable to RAPID SPRAY products, and to the maximum extent permitted by law, overrides any other conditions or warranties expressed or implied on RAPID SPRAY products.

Other than legislative obligations to the contrary, RAPID SPRAY will not be liable for and incidental or consequential damages arising from the ownership or use of a product. No person, including any dealer or representative of RAPID SPRAY is authorized to make any representation or warranty on behalf of RAPID SPRAY in addition or inconsistent with these provisions. Purchasers to whom these provisions apply agree to hold RAPID SPRAY not liable for claims by their customers in excess of the obligations of RAPID SPRAY expressly set forth herein.

NOTE: All tank and spray systems must have their warranty activated by returning the warranty card located at the end of this document within 21 days of purchase by the end user.

The Warranty

All products sold by RAPID SPRAY are guaranteed to be free from defect in materials workmanship or manufacture for a period of 12 months from the initial date of purchase, excepting the following exclusions;

Any parts/products found by RAPID SPRAY to be defective, either in material or workmanship will be replaced or repaired within this period, at no cost to the initial purchaser if following conditions are met:

- The item has been operated in accordance with all instructions and warnings provided
- Item is still owned and operated by the original purchaser - proof of purchase is required to obtain warranty

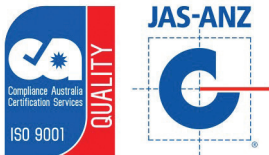

WWW.JAS-ANZ.ORG/REGISTER

FOLLOWING THINGS ARE EXPRESSLY EXCLUDED FROM THE ABOVE WARRANTY.

ABUSE	Failure as a result of neglect, such as improper operation. Lack of maintenance or continued operation after discovery of a defect that leads to further damage
ALTERATIONS	Any unauthorized alteration, modification, attachments or unauthorized repair to equipment.
CLEAN-UP TIME	RAPID SPRAY does not pay for cleaning of products, parts or accessories or work area before or after the warranty repair.
DAMAGE	Damages or machine/component failure caused by carelessness/recklessness or accidental damage, improper operation, excessive speed, inappropriate storage or transportation.
ENVIRONMENTAL CONDITIONS & APPLICATION	Deteriorated or failed components such as o-rings, diaphragms, hoses, seals and connections damaged by corrosive chemicals, dirt and sand, excessive heat, moisture or other environmental impacts. Warranty determination on these type of failures will be made by RAPID SPRAY, only after inspection of the failed component.
INABILITY UNSUITABILITY	In no event shall RAPID SPRAY be liable to any person for indirect or consequential damages or for injury or commercial loss resulting from any use or inability to use any RAPID SPRAY product.
MAINTENANCE	Component failure due to failure to perform maintenance services such as, oil and grease changes/top-ups, failure to clean tanks, pumps filters, nozzles and spray lines. Failure to tighten or replace loose or missing bolts, nuts, fittings, shields and covers.
NON-GENUINE PARTS	Use of parts other than RAPID SPRAY parts for repair of warranted items will automatically negate any warranty. Warranted components must be replaced with genuine parts.

This page has been left blank intentionally.

WARRANTY REGISTRATION

You can register online at www.rapidspray.net/resources/warranty-registration or complete all the details below and post this form back to:

Rapid Spray, PO Box 3119, Singleton NSW 2330

Model Serial No

Purchased From
(Dealer Name & Town)

Purchaser's Name

Purchaser's Address
.....

Purchaser's Phone Number

Disclaimer: If you don't want us to keep you informed of new products, please tick the following circle:

To help us help you further, please complete the following:

Purchaser's Age

- Up to 25
- 25 - 40
- 41 - 55
- Over 55

Principal Usage

- Commercial farm
- Hobby farm
- Industrial
- Other.....
- Town council
- Hire company
- Home

What influenced you to purchase a Rapid Spray product?

- Received Catalogue
- Newspaper advertisement
- Magazine advertisement
- Dealer recommendation
- Friends recommendation
- Better features than competitor product
- Quality & reliability
- Price
- Past experience with Rapid Spray products
- Other.....

What other Rapid Spray products do you use?

- Spray tanks
- Cartage tanks
- Diesel tanks
- Fire fighting
- Boom sprayers
- Bertolini pumps & controllers
- Inter knapsacks | Compression sprayers
- Other.....





Call us on 1800 011 000 or visit www.rapidspray.net

35 Enterprise Cres, Singleton NSW 2330
PO BOX 3119 Singleton NSW 2330

Telephone: 1800 011 000
Facsimile: 02 6571 2951

Rapid Spray Liquid Management Systems

