



MARSHAL PRO

OPERATORS HANDBOOK



MARSHAL PRO
BUDDY MARSHAL PRO

250L



CONTENTS

- 01** Introduction & Models
- 02** Warnings
- 03** Product Risk Assessment
- 04** Troubleshooting
- 05** Operation
- 06** Mixing & Filling
- 07** Calibration Guides
- 08** Spraying
- 10** Buddy Smart Reel Operation
- 12** Boom Regulator Kit
- 13** Honda GX200 Engine
- 19** Cleaning & Maintenance
- 21** Marshal Tank Parts Breakdown
- 22** Maruyama 33L/min Pump Breakdown
- 24** Turbo 400 Spray Gun Parts Breakdown
- 25** Pistol Grip Spray Gun Parts Breakdown
- 26** Warranty
- 29** Warranty Registration



INTRODUCTION

Thank you for your purchase of a Rapid Spray Marshal Pro, a powerful, compact UTV sprayer ready to mount to your UTV* or back of ute.

MODELS

Please note your unit may not have all the parts or accessories listed in this handbook.

This handbook covers the following models (including any custom variations):

MARSHAL PRO RANGE



SU0250AL0330H3
SU0250AL0330H5

BUDDY MARSHAL PRO RANGE



SU0250AL0330R5
SU0250AL0330R18

DISCLAIMER: In line with our policy of continuous improvement, the weights, dimensions and design may change slightly from what is shown in this operators handbook.

***WARNING:** Always obey vehicle and UTV/ATV manufacturer instructions regarding loading and operation. Please check weight restrictions. Serious death or injury can occur from improper usage. Rapid Spray accepts no liability for the unsafe operation of this unit.

WARNINGS

Read all warnings below and obey any instruction stickers or warnings on the spray unit. Failure to do so may result in serious bodily harm or death.

1. When mounting to any vehicle, ensure that you have read the Vehicle Owner's Manual and that you comply with all the weight restrictions as specified by the vehicle manufacturer, as overloading can cause injury or death. Remember that one litre of water weighs one kilogram. Ensure equipment is secure during transport.
2. To ensure your own safety and that of your employees or colleagues (if applicable) you must comply with all relevant environmental, work place health and safety legislation and codes of practice.
3. You must be in good mental health to operate this sprayer and not be under the influence of alcohol or any drugs that could impair your vision, physical strength, dexterity, judgment or other mental capacity.
4. Improper or careless use of this sprayer can cause serious injury. Minors should never be allowed to use this sprayer. This sprayer should not be used when bystanders or animals are in the area. This sprayer should never be used while children are in the area.
5. Before spraying, check the electrical and fuel systems for damage and deterioration. Replace parts as necessary. Do not modify the equipment or use any attachments other than those specified by the manufacturer.
6. Select and wear appropriate Personal Protective Equipment (PPE) in accordance with the label of the product you intend on using and your own safe work practices. PPE must still be worn while decontaminating your sprayer. Any accidental spills on the skin must be immediately be washed with clean water and soap.
7. Turn off the engine before filling the chemical tank. Spray during the morning or evening when it is cool. Intense sunlight will condense chemicals and may cause damage. Care should be taken when spraying in windy conditions as spray drift may contaminate the air and may affect the operator or damage adjacent non-target vegetation.
8. Spray only in well ventilated areas to keep away from flames or cigarettes. Keep all hoses and equipment away from the hot engine to avoid fire hazards.
9. Do not eat, drink or smoke while spraying to avoid ingestion of chemicals. Do not carry or store lunch boxes or other food and drink with spraying equipment.
10. Once the spraying operation has been completed, decontaminate the spray tank and spray accessories. Store any remaining chemicals in a safe place in a sealed container. Dispose of tank rinsing in compliance with the current environmental, work place health and safety regulations.
11. Never leave the sprayer unattended without turning off the engine and relieving the line pressure, and flushing the sprayer of any harmful chemicals.
12. Carry out maintenance as per the recommendations. Ensure that the unit is cool and securely stabilised on a level surface before commencing maintenance.

PRODUCT RISK ASSESSMENT

TASK	HAZARDS	RISK	CONTROL MEASURES
Partially fill the tank with water, start the motor and test the spray unit.	Manual handling; slips, trips or falls; petrol fumes; fingers jammed	Medium	Concentrate on tasks, follow safe manual handling techniques: don't lift on your own if > 20kg, bend knees, keep back straight; keep fingers clear; keep unit at least 8m away from overhead power-lines; fire extinguisher nearby; follow warning stickers on tanks; wear PPE for petrol and fumes (mask and gloves)
Check weather and ground conditions and select the appropriate PPE to suit the chemicals to be used.	Manual handling; slips, trips or falls.	Low	Put on PPE as per the chemical requirements in the Material Safety Data Sheet (MSDS) - coveralls, gloves and respirator; follow safe manual handling techniques: don't lift on your own if > 20kg, bend knees and keep back straight
Mix chemicals and fill spray tank units	As above; spray drift, chemical spillage, emission of vapours or flammability: weather; untrained visitors.	Medium	As above; user trained in the state's chemical mixing and administration course e.g. Chem Cert; follow the relevant Environment Protection Authority requirements, fire extinguisher present; keep visitors away from the job unless wearing full PPE
Use spray unit	As above; loss of load; work in heat & cold; noise; exceed load limit of vehicle; hose entanglement; terrain and slopes	High	As above; wear clothes to suit heat and cold; wear hearing protection if pump noise > 85 dBA; follow manufacturer's safe operation instructions for the vehicle and spray unit; don't overload - water weighs 1kg per 1L; secure load to vehicle; hose tidy
Clean up, maintenance and storage	As above	Low	As above; continue to wear PPE for clean-up, store tank in dry, well ventilated area
Buddy Smart Reel®			See Buddy Smart Reel® Operators Handbook
Pump / Motor			See pump / motor Operators Handbook

TROUBLESHOOTING

CONDITION	CAUSE	REMEDY
Pump will not prime	<ol style="list-style-type: none"> 1. Insufficient motor RPM 2. Air leak on suction plumbing 3. Blocked/ restricted intake hose 4. Filter cap disengaged 5. Filter gasket damaged / missing 	<ol style="list-style-type: none"> 1. Increase motor RPM until pump primes 2. Tighten/ replace fittings and hose clamps. Verify suction hoses are in good condition. 3. Remove blockage from suction line, ensure line is not kinked. 4. Lock filter cap into position. 5. Replace filter gasket.
Pressure drops / fluctuates during standard operation	<ol style="list-style-type: none"> 1. Restriction on suction line 2. Pump sucking air 3. Plugged filter 4. Damaged regulator 	<ol style="list-style-type: none"> 1. Inspect tank and suction lines and remove restriction 2. Tighten fittings 3. Remove and clean filter mesh and housing 4. Remove regulator stem and inspect for broken parts / pieces
Pressure gauge not registering	<ol style="list-style-type: none"> 1. Plugged with debris 	<ol style="list-style-type: none"> 1. Unthread, check and clean pressure gauge
Hand gun loses pressure	<ol style="list-style-type: none"> 1. Debris in hose or nozzle 2. Pump losing prime 3. Pump pressure dropping / fluctuating 	<ol style="list-style-type: none"> 1. Unthread nozzle tip and clean 2. See 'Remedy' for 'Pump will not prime' 3. See 'Remedy' for 'Pressure drops / fluctuates during standard operation'
Buddy Smart Reel®		See Buddy Smart Reel® Operators Handbook
Pump / Motor		See pump / motor Operator's Handbook

! WARNING !

Always obey vehicle and UTV/ATV manufacturer instructions regarding loading and operation. Please check weight restrictions. Serious death or injury can occur from improper usage. Rapid Spray accepts no liability for the unsafe operation of this unit.

OPERATION

PRE-START UP

1. Familiarise yourself with the unit.
2. Inspect the unit for any broken or damaged components - replace damaged/broken components as necessary.
3. Familiarise yourself with the HONDA motor instructions as per pages 12 - 17, and ensure you follow all warnings and instructions. For further instructions read the Honda Owners Manual.

WARNING: the motor is shipped without oil or fuel - before operation, fill the motor with the correct oil and fuel as advised in the HONDA motor instruction manual.

START UP

1. Confirm tank contents contains chemical/water.
2. Set the throttle lever to the 'LOW' position. Set the choke lever to the 'CLOSE' position when the engine is cold.
3. Turn the pressure regulating knob anti-clockwise to the 'BYPASS ("0" pressure) position.
4. While holding the sprayer steady, grip the recoil starter handle and pull quickly.
5. While checking the engine status after start-up, return the choke lever to the 'OPEN' position.

Allow engine to warm-up for 2-3 minutes before commencing spraying operation.

OPERATION - Manipulating the pressure regulating valve

Turn the pressure regulating knob clockwise to increase pressure, and anti-clockwise to decrease pressure. The sprayer requires less power when the regulating valve is set to low pressure or the flow requirements are low. Running the engine with the throttle lever fully open will result in unnecessary noise and increased fuel consumption. It is recommended to operate with the throttle lever at a medium setting.

For boom regulator operating instructions see page 12.

MIXING & FILLING

The following steps are given as a guide to mixing and filling your Marshal Pro sprayer.

1. Read the product label and follow the instructions carefully, taking special note with regard to the order in which the products are added to the tank.

CAUTION: Mixing sites must be well away from watercourses and other environmental sensitive areas. Children and animals must be kept away.

2. Measure out the correct quantity of chemical using clean measuring jugs used only for this purpose.
3. Half fill the sprayer with clean water.
4. Commence agitation of the Marshal Plus with following steps:
 - Pressure control lever must be in the 'by-pass' position. Turn regulator valve knob in an anti-clockwise direction to reduce pressure to 'O' bar.
 - Add the chemicals as measured correctly to the spray tank while still agitating.
 - Rinse out the measuring jug and pour all rinsing's into the spray tank. Safely dispose of empty containers in compliance with current regulations.
 - Top up the tank with water to the required level; ensure that the tank is not over-filled and the outside is clean and dry before handling.
 - Your Marshal Plus has now been correctly filled and the product thoroughly mixed. Spraying can now commence.
5. To commence spraying, move the pressure control lever clockwise to the 'press' position, close the spray gun or boom and turn the adjustment knob in an anti-clockwise direction until your desired pressure has been reached. Open the spray gun or boom and start spraying.



CALIBRATION GUIDE

Accurate calibration is an essential element of any spraying function as it ensure that the pesticide is applied at the rate as recommended by the product manufacturer. Application in excess of the recommended rate is prohibited, can damage crops and is uneconomical. View the products packaging for recommended spraying applications.

Calibration must always be carried out:

- Spraying for the first time with new spray equipment
- At the beginning of each season
- After changes of nozzle tips, spraying pressure or speed
- After every 100 hectares of spraying
- Changes in pesticide

NOTE: When calibrating a sprayer, appropriate personal protective wear should be worn.

STEP-BY-STEP CALIBRATION GUIDE		EXAMPLE
Read the label. Find the following:	Spray Volume (VOLUME) Product Dose Spray QUALITY	200L / hectare 50L / hectare Medium
Measure: Time / 100m	Measure time to spray 100m in seconds over land similar to that which will be sprayed.	41.9 seconds
Calculate: SPEED	Speed (km/h) = 360 divided by time (seconds)	$\frac{360}{41.9} = 8.6\text{km/h}$
Measure nozzle SPACING	Distance between each nozzle	0.5m
Measure: L/min OUTPUT	Output = VOLUME x SPEED x SPACE ÷ 600 (L/min) (L/hectare) (km/h) (metre)	$200 \times 8.6 \times 0.5 \div 600$ Output = 1.433L/min
Choose NOZZLE	Refer to nozzle manufacturers data charts or other sources and select the size and type of nozzle that will product the calculated OUTPUT and spray QUALITY	
Now, check the calibration on the sprayer.		
Check Nozzle OUTPUT	With water, check outputs of 4 or more nozzles using a calibrated jug or flow meter. Check all nozzles are aligned correctly and spray patterns are good.	Average Output = 41.9L/minute
Calibrate Sprayer	SPRAY VOLUME = OUTPUT x 600 ÷ SPEED ÷ SPACE (L/min) (km/H) (metre)	$1.4 \times 600 \div 8.6 \div 0.5 = 195$

If, as in the example, the nozzle output and therefore, spray volume, is less than the recommended figures, increase the pressure and repeat calibration until target spray volume is reached.

SPRAYING

For effective spraying, ensure you have taken the following factors into account.

1. Before commencing spraying, plan the work effectively to reduce potential contamination.
2. Do not spray if the operator, bystanders, watercourses or any non-target vegetation appears to be in danger from spray drift contamination.
3. Work Rates
 - Speed of operation
 - Water points or nurse tanks
 - Rate of travel
 - Swath width
 - Spray volume applied
4. Wind and drift
 - Wind speed
 - Wind direction
 - Airspeed at boom height
 - Wind direction and drift is controlled by;
 - » Reducing nozzle height
 - » Reducing pressure and using larger nozzles
 - » Fit low-drift nozzles producing larger droplets

NOTE: Avoid spraying on still warm days or during the night as convection currents may cause drift in unpredictable directions. Optimum wind speeds are between 3km/h to 7km/h.



5. Field Work (for use with boom attachment - see diagram on page 9)
 - Swath marking and spraying
 - Mark out to ensure proper pass matching - use flags, foam markers or tram-lines
 - Where large obstacles exist in the middle of an area to be sprayed, mark out and spray the area like a separate headland.
 - The perimeter of the field should be sprayed first. The width of two swaths will give adequate turning space at the ends of spray runs.
 - Never spray while turning.
6. Maintain constant speed when spraying. Should you need to increase your spraying speed, larger delivery nozzles must be fitted. Re-calibrate as required.

BUDDY SMART REEL® (if applicable)

Please read the Buddy Smart Reel® Operators Handbook for full instructions, parts and maintenance instructions.





Please note your Marshal Pro sprayer may not require the following instructions. Only applicable to Buddy® Marshal Pro sprayer units.

OPERATION

1. Switch power to the Reel and confirm that the display shows .
2. Pull the hose out to the required length for spraying.
3. To retract hose at maximum speed, press the  button on the MyPace remote.
4. To retract the hose at a slower speed, press the  button on the MyPace remote. Always maintain a slight pull on the hose as it is rewinding to ensure a consistent layout of the hose on the spool.
5. Please note that the reel must not be connected to a pressure reading that is greater than 40Bar.
6. Connect the spray gun to the fitting at the end of the hose.
7. In case of a misplaced remote the button on the switch panel will operate as a manual fast rewind.

SETTING/CHANGING CUSTOM SPEED MYPACE REMOTE

The MyPace function allows a custom rewind speed to be set and stored. It can easily be re-calibrated as often as needed to suit changing conditions in terrain, weather or each operator's personal preference.

1. Pull the hose out to at least 20m.
2. Press both   buttons on the MyPace handheld remote.
3. The Buddy® hose reel will begin to rewind at its minimum speed. The speed will gradually increase while both buttons remain pressed.
4. When the desired speed is reached, release the  button and the reel will continue at that set speed. (If both buttons are held for approximately 20 seconds the reel will reach maximum speed).
5. Releasing both buttons will cause the custom speed to be stored in the memory of the remote.
6. When the  button is pressed the reel will operate at the set speed.
7. The custom speed can be reset as often as needed by starting back at step 2.





PAIRING MYPACE REMOTE TO BUDDY SMART REEL®

The MyPace handheld remote should be delivered already paired to the Buddy Hose Reel. If several reels have been purchased and it is not clear as to which remote is paired to which reel or if the remote has been replaced, the remote can be re-paired to the reel at any time.

How to pair the MyPace remote

1. Stand within reach of the Buddy Reel switch panel.
2. Ensure the reel is powered and switched on.
3. Remove the batteries from the remote.
4. Press both buttons on the remote and insert the batteries while holding the buttons.
5. Green lights will flash slowly on the remote and the display on the switch panel on the reel will slowly flash **PA**.
6. Within 10 seconds, press the manual rewind button on the reel switch panel.
7. Successful pairing will be acknowledged by the display on switch panel flashing **PA** fast for a few seconds then return to a steady **□**. (The green light on the remote may continue to flash slowly for a few seconds then stop).
8. After the green light on the remote stops flashing, press either button to confirm that the reel is responding.

READING LED LIGHTS & SWITCH PANEL CODES

	Slow flash	Unit in pairing mode		Very fast flash	Battery low and fast rewind pressed
	Very fast flash	Fast rewind button pressed		Fast flash	Battery low and slow rewind pressed
	Fast flash	Slow rewind button pressed			

Your Buddy Smart Reel® is equipped with a display to indicate its current status. During operation of your reel you may observe the following messages on the display.

- **□** = Reel powered correctly, on standby, ready to operate
- **PA** = Reel has not been paired to a remote
- **PA** = Reel is in pairing mode
- **LL** = Supply voltage to reel is too low
- **FR** = Reel is rewinding at the fast setting
- **SL** = Reel is rewinding at the slow speed

BOOM REGULATOR KIT | ATRVS10B400P

If your Marshal Pro sprayer has been fitted with a low pressure boom regulation kit and solenoid, you can use this to accurately regulator the output pressure for boom or boomless nozzle spraying.

SETUP & OPERATION

1. Connect the solenoid battery clips to your 12 volt DC power source;
2. Connect your boom or boomless nozzle to the ½" MBSP outlet fitting or supplied 10mm hose tail which exits the solenoid valve;
3. Turn the regulator control t-bar (silver) anti-clockwise until it is completely open. Loosen the locking nut if required;
4. Turn on the pump and adjust the main high pressure regulator (black knob) to 10bar;
5. Open the small ball valve on the high pressure manifold to allow liquid to enter the low pressure regulator;
6. Slowly turn the t-bar control on the low pressure regulator clockwise until the desired pressure is reached on the gauge while spraying out of the boom/boomless nozzle;

NOTE: if you are using high pressure to spray with the hand gun, you will need to turn off the tap feeding the low pressure manifold or you will not be able to increase the pressure past 15bar.

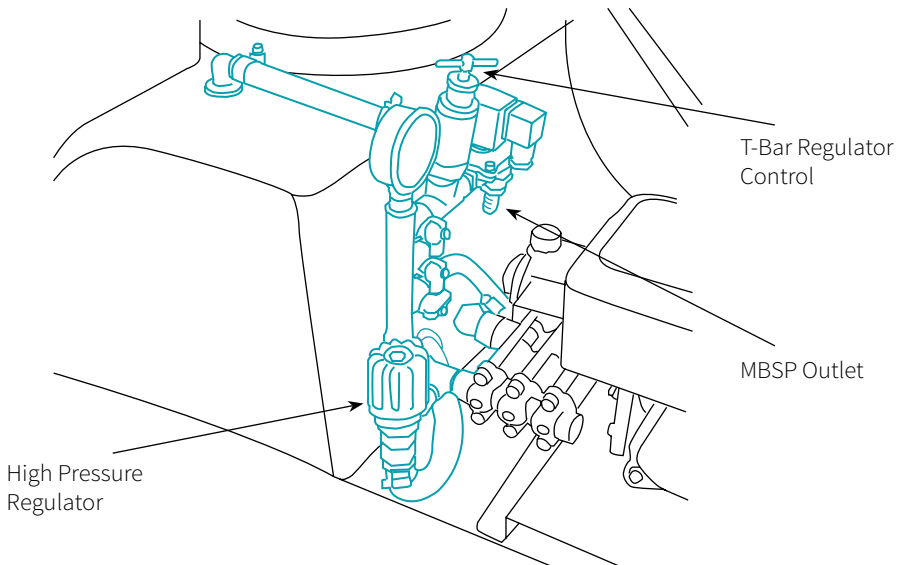

HONDA GX200 ENGINE

Please read the Honda® Owners Manual for full safety, operation, parts and maintenance instructions. Always follow manufacturers directions.

SAFETY INFORMATION

- Understand the operation of all controls and learn how to stop the engine quickly in case of emergency. Make sure the operator receives adequate instruction before operating the equipment.
- Do not allow children to operate the engine. Keep children and pets away from the area of operation.
- Your engine’s exhaust contains poisonous carbon monoxide. Do not run the engine without adequate ventilation and never run the engine indoors.
- The engine and exhaust become very hot during operation. Keep the engine at least 1m (3 ft) away from buildings and other equipment during operation. Keep flammable materials away, and do not place anything on the engine while it is running.

SAFETY LABELS

This label warns you of potential hazards that can cause serious injury. Read it carefully. If the label comes off or becomes hard to read, contact your Honda servicing dealer for a replacement.

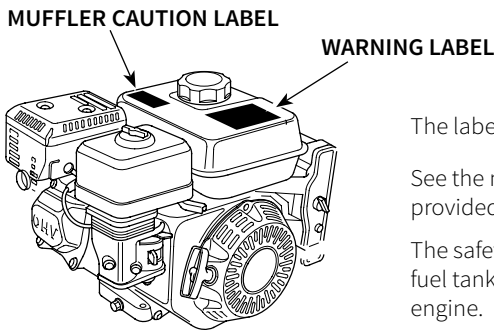

The label is packaged with the engine.

See the manufacturer’s instructions provided with the equipment.

The safety label should be located on the fuel tank or packaged loosely with the engine.

MUFFLER CAUTION LABEL

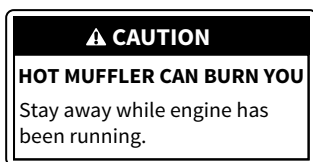

WARNING LABEL

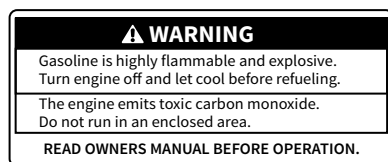

COMPONENT & CONTROL LOCATIONS

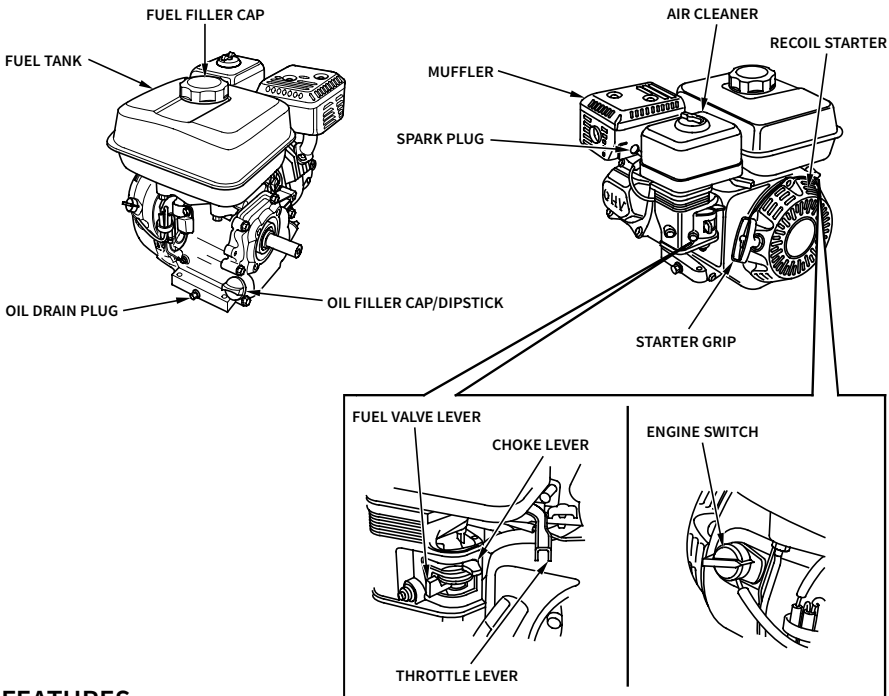

FEATURES

Oil Alert® System

The Oil Alert® system is designed to prevent engine damage caused by an insufficient amount of oil in the crankcase. Before the oil level in the crankcase can fall below a safe limit, the Oil Alert® system will automatically stop the engine (the engine switch will remain in the ON position).

If the engine stops and will not restart, check the engine oil level before troubleshooting other areas.



BEFORE OPERATION CHECKS

Is your engine ready to go?

For your safety, and to maximise the service life of your equipment, it is very important to take a few moments before you operate the engine to check its condition. Be sure to take care of any problem you find, or have your servicing dealer correct it before you operate the engine.

WARNING

Improperly maintaining this engine, or failure to correct a problem before operation can cause a malfunction in which you can be seriously hurt or killed.

Always perform a pre-operation inspection before each operation and correct any problem.

Before beginning your pre-operation checks, be sure the engine is level and the engine switch is in the OFF position.

Always check the following items before you start the engine:

Check the General Condition of the Engine

1. Look around and underneath the engine for signs of oil or gasoline leaks.
2. Remove any excessive dirt or debris, especially around the muffler and recoil starter.
3. Look for signs of damage.
4. Check that all shields and covers are in place, and all nuts, bolts and screws are tightened.

Check the Engine

1. Check the fuel level. Starting with a full tank will help eliminate or reduce operating interruptions for refuelling.
2. Check the engine oil level. Running the engine with a low oil level can cause engine damage.

The Oil Alert® system will automatically stop the engine before the oil level falls below safe limits. However, to avoid the inconvenience of an unexpected shutdown, always check the engine oil level before startup.

3. Check the air filter elements. A dirty air filter element will restrict air flow to the carburetor, reducing engine performance.
4. Check the equipment powered by this engine.

Review the instructions provided with the equipment powered by this engine for any precautions and procedures that should be followed before engine startup.

SAFE OPERATING PRECAUTIONS

Before operating the engine for the first time, please review the SAFETY INFORMATION section and the BEFORE OPERATIONS CHECKS on previous cards.

For your safety, do not operate the engine in an enclosed area such as a garage. Your engine's exhaust contains poisonous carbon monoxide gas that can collect rapidly in an enclosed area and cause illness or death.

WARNING

Exhaust contains poisonous carbon monoxide gas that can build up to dangerous levels in closed areas. Breathing carbon monoxide can cause unconsciousness or death.

Never run the engine in a closed or even partly closed area where people may be present.

Review the instructions provided with the equipment powered by this engine for any safety precautions that should be observed with engine startup, shutdown or operation.

Do not operate the engine on slopes greater than 20°.

STARTING THE ENGINE

1. Move the fuel valve lever to the ON position.

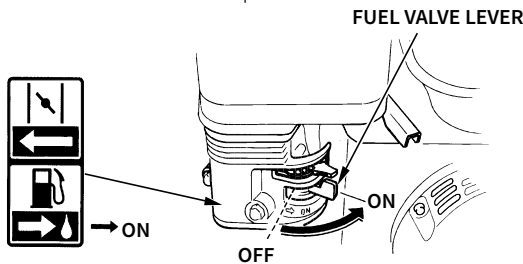

2. To start a cold engine, move the choke lever to the CLOSED position.

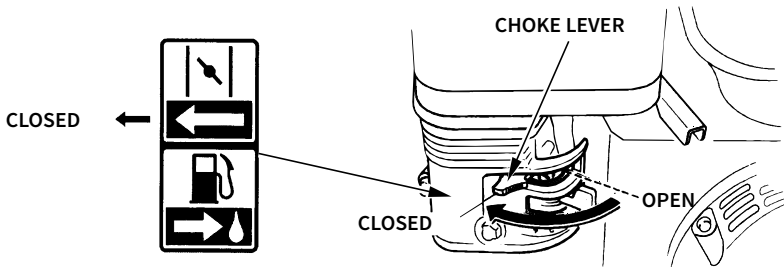

To restart a warm engine, leave the choke lever in the OPEN position.

STARTING THE ENGINE cont.

- 3. Move the throttle lever away from the MIN. position, about 1/3 of the way toward the MAX. position.

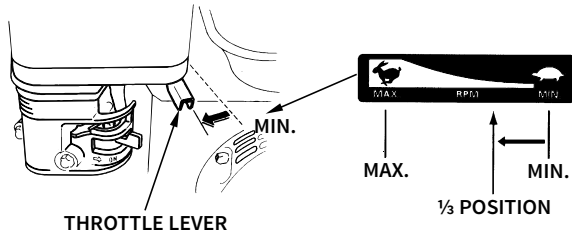

Some engine applications use a remote-mounted throttle control rather than the engine mounted throttle level shown here. Refer to the instructions provided by the equipment manufacturer.

- 4. Turn the engine switch to the ON position.

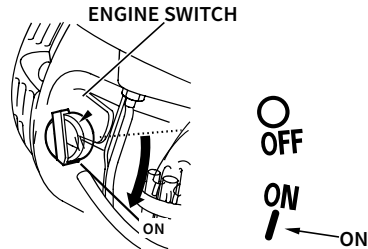

- 5. Pull the starter grip lightly until you feel resistance, then pull briskly in the direction of the arrow shown below. Return the starter grip gently.

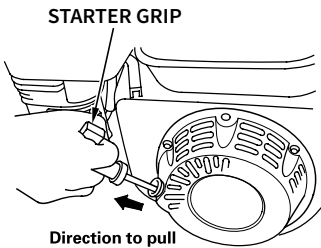

NOTICE

Do not allow the starter grip to snap back against the engine. Return it gently to prevent damage to the starter.

- 5. If the choke lever was moved to the CLOSED position to start the engine, gradually move it to the OPEN position as the engine warms up.

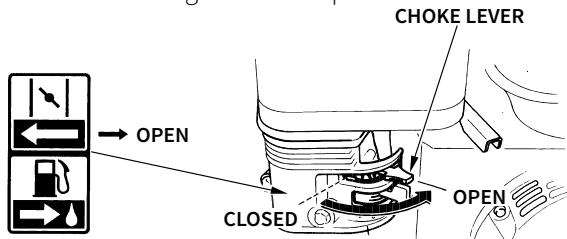

STOPPING THE ENGINE

To stop the engine in an emergency, simply turn the engine switch to the OFF position. Under normal conditions, use the following procedure.

1. Move the throttle level to the MIN. position.

Some engine applications use a remote-mounted throttle control rather than the engine mounted lever shown here.

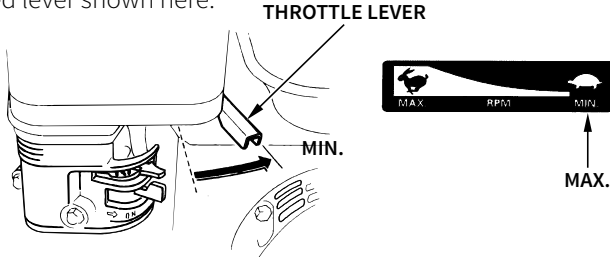

2. Turn the engine switch to the OFF position.

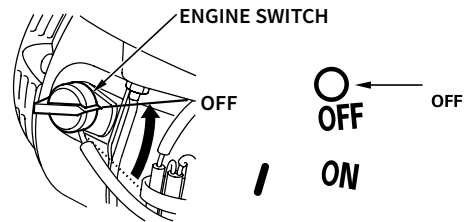

3. Turn the fuel valve lever to the OFF position.

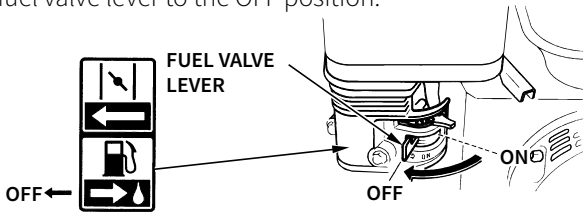

SETTING THE ENGINE SPEED

Position the throttle lever for the desired engine speed.

Some engine applications use a remote-mounted throttle control rather than the engine mounted throttle lever shown here.

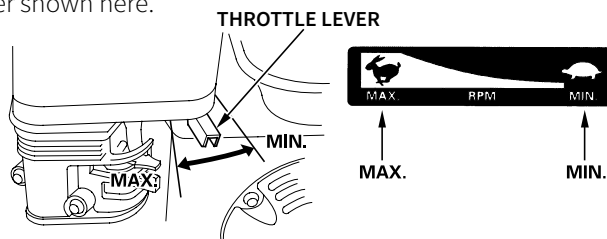

CLEANING & MAINTENANCE

After use, the sprayer must be thoroughly decontaminated, inside and outside. Decontaminating the tank, including pumps, hoses and hand lance, avoids damage to crops from harmful spray residues and prevents sprayer corrosion and abrasion. As a guide, follow the decontamination procedure below:

1. After spraying, rinse all liquid out of the tank.
NOTE: When flushing the sprayer, pay attention to where the chemical will run. Always clean in an area that will not contaminate water sources or crops.
2. After draining the tank, rinse the inside by spraying clean water with a pressure washer.
3. Turn the pump off and fill the tank with clean water and a recommended cleaning liquid.
NOTE: to ensure any pesticide residue is removed from the tank, let the water and cleaning solution sit for 8 hours.
4. The suction filter mounted on the sprayer frame must be cleaned regularly. Unscrew the filter cover and remove the filter screen and gasket. Soak in clean water, brushing with a nozzle brush. Ensure gasket is in position when re-assembling.
5. The filter basket strainer is removed by lifting it out of the filler ring. Clean the basket strainer the same way as the suction filter. Replace the basket strainer by exerting a quick downward push ensuring the strainer has seated correctly.
6. Nozzles, nozzle filters, nozzle caps and gaskets should be cleaned by soaking in water, brushing with a nozzle brush and allowed to dry. Never blow through the nozzles with your mouth or use wire or pins to clear blockages. When re-assembling, ensure that the nozzle cap gasket is correctly positioned.
7. Ensuring all nozzles, filters etc. are back in place, flush the water through the entire system; turn the pump on and spray the clean water through the booms and hand lance.
8. When storing the sprayer, ensure that it is clean and dry. Keep in a well ventilated place.

CLEANING & MAINTENANCE cont.

Maintenance to pump and engine should be carried out regularly. Refer to pump and engine handbooks for Maintenance Schedule.

PUMP MAINTENANCE

Check pump Operators Handbook for maintenance schedule and further instructions.

- Check to make sure that all screws are tightened and that no parts are missing.
- Check to make sure there are no loose connections on hoses, nozzle, lance or valves.
- Thoroughly clean the nozzle and filter. Take the cap off the filter housing and remove filter screen for cleaning. Ensure filter screen is properly located before screwing cap back on.

INSPECT THE ENGINE - All repairs to be carried out by certified Honda dealer.

Check engine Honda Owners Manual for maintenance schedule and further instructions.

- Check to make sure there are no loose or missing screws in any part of the engine.
- Clean the air filter regularly - particularly if working in a dusty environment.
- Clean and adjust the spark plug as necessary.
- Clean the cooling fan, air intake opening and parts around the muffler.
- Check the engine oil and change it as necessary.
- Inspect the fuel line filter, check for fuel leaks.

LONG TERM CLEANING & STORAGE

- When storing the sprayer, ensure that it is clean and dry and kept in a ventilated place where it will not be subject to freezing temperatures. Frozen water may crack metal components and void warranty.
- Completely drain any water from the pump.
- Pull the recoil started handle slowly until there is no resistance.
- After removing the fuel from the tank, push the priming pump until fuel in the line runs out. Remove fuel from the tank once more.
- Check the engine oil and change if necessary.
- Set the throttle lever in the low speed position.
- Wipe away any dirt or dust.

MARSHAL TANK PARTS BREAKDOWN

250L MARSHAL TANK

910 (L) x 730 (W) x 620 (H)

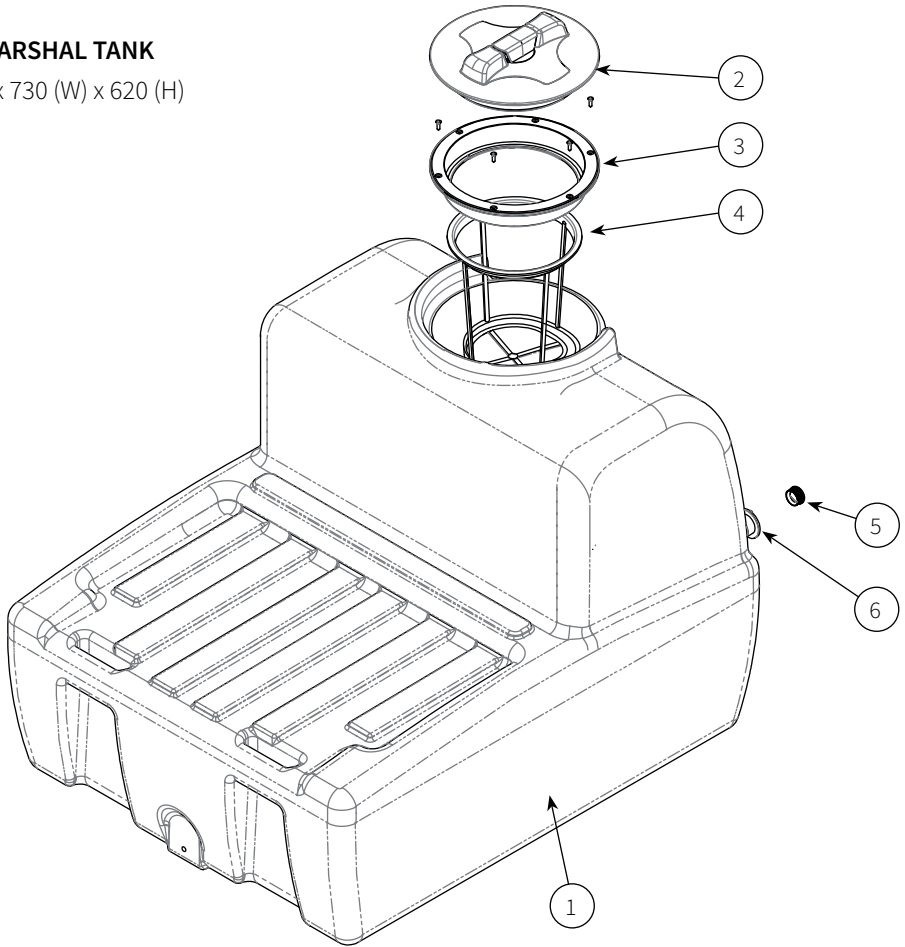

#	Part No.	Qty	Description
1	AMPTC00200ATT	1	200L Marshal Tank
2, 3, 4	ARLP250VSR	1	255mm Screw Lid
5, 6	CFNB20M	1	3/4" poly Drain Bung & Seal

MARUYAMA 33L/MIN PUMP

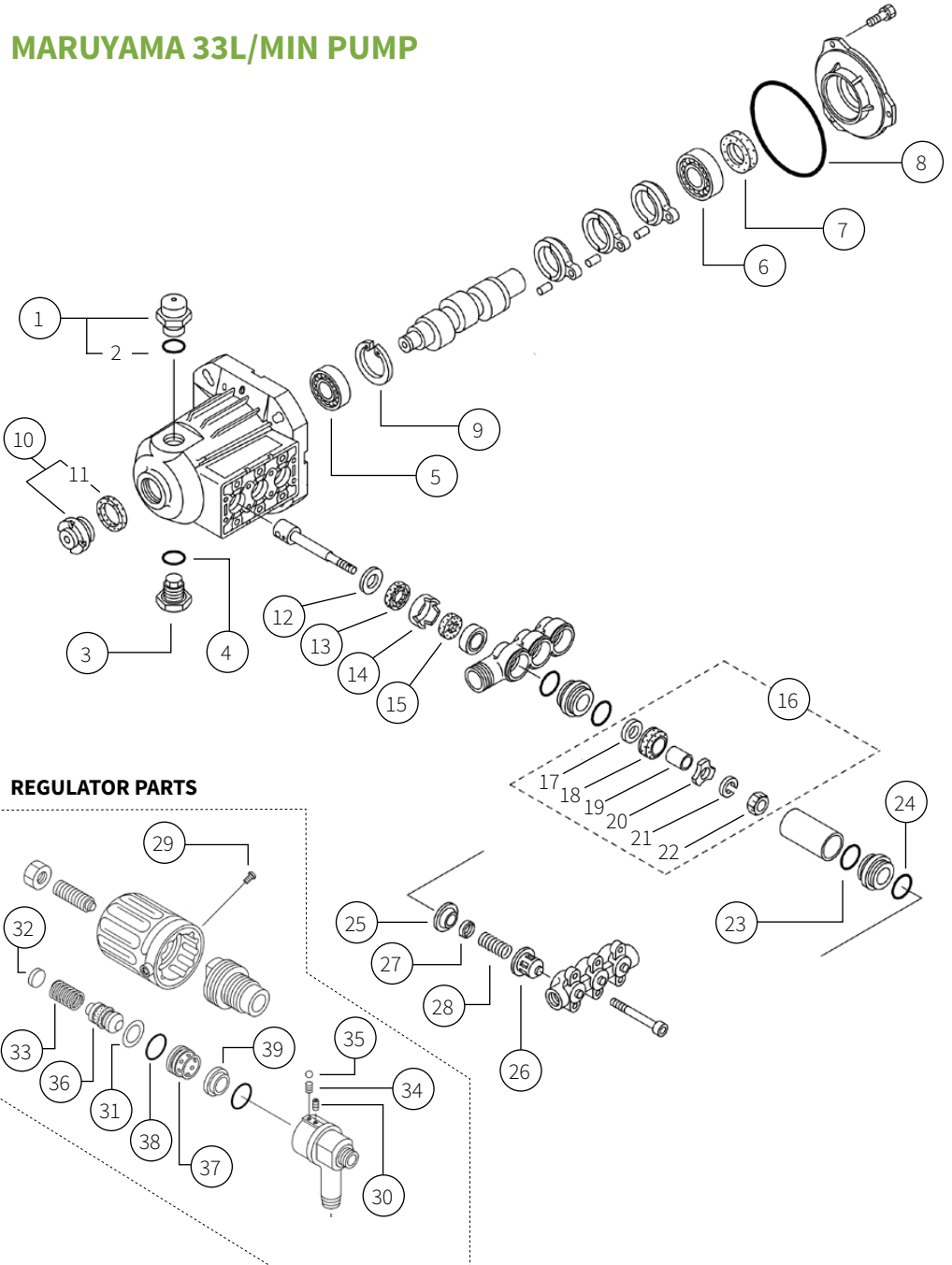

REGULATOR PARTS

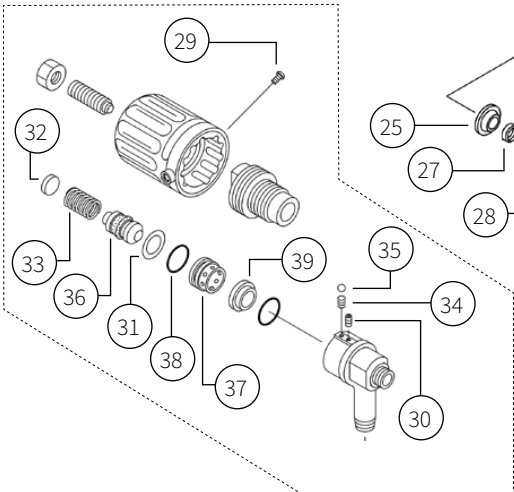

#	Description	Qty
1	CPUXK330S - Oil Filter Cap incl. #2	1
2	O-Ring P20	1
CPUXL330V - Valve Repair Kit		
3	Plug	1
4	O-Ring P20	1
5	#6204 Bearing	1
6	#6006 Bearing	1
7	D30428 Oil Seal	1
8	S100 O-Ring	1
9	Snap Ring	1
10	Oil Gauge incl. #10-2	1
11	Packing	1
12	17x24xT1.2 Washer	3
13	S10.5247 Oil Seal	3
14	Seal Retainer	3
15	10x19x5 Oil Wick	3
16	A Block incl #16-1 - 16-7	3
17	Inlet Valve Set	3
18	Piston Packing Set	3
19	6x8.5x10.5 Spacer	3
20	Piston Retainer	3
21	M6 Spring Washer	3
22	M6 Nut	3
CPUXK330G - Plunger Kit		
18	Piston Packing Set	3
22	M6 Nut	3
23	P21 O-Ring	6
24	P22 O-Ring	6
CPUXK330S - Seals Kit		
25	Valve Seat	3
26	Valve Sack Retainer	3
27	16x1.5 Valve	3
28	0.6-15L Spring	3
CPUXK330R - Regulator Repair Kit		
29	M3xP0.5x5 Screw	2
30	M4x6 Hexagon Socket Screw	1
31	16x21x0.7T Washer	1
32	15xT2.5 Spring Seat	1
33	3.0-31L Spring	1
34	0.6 - 7L Spring	1
35	5/32 Valve Ball	1
36	Piston Assembly	1
37	Sleeve	1
38	P16 O-Ring	1
39	Valve Seat	1

TURBO 400 SPRAY GUN | AHG103

Marshal Pro Range

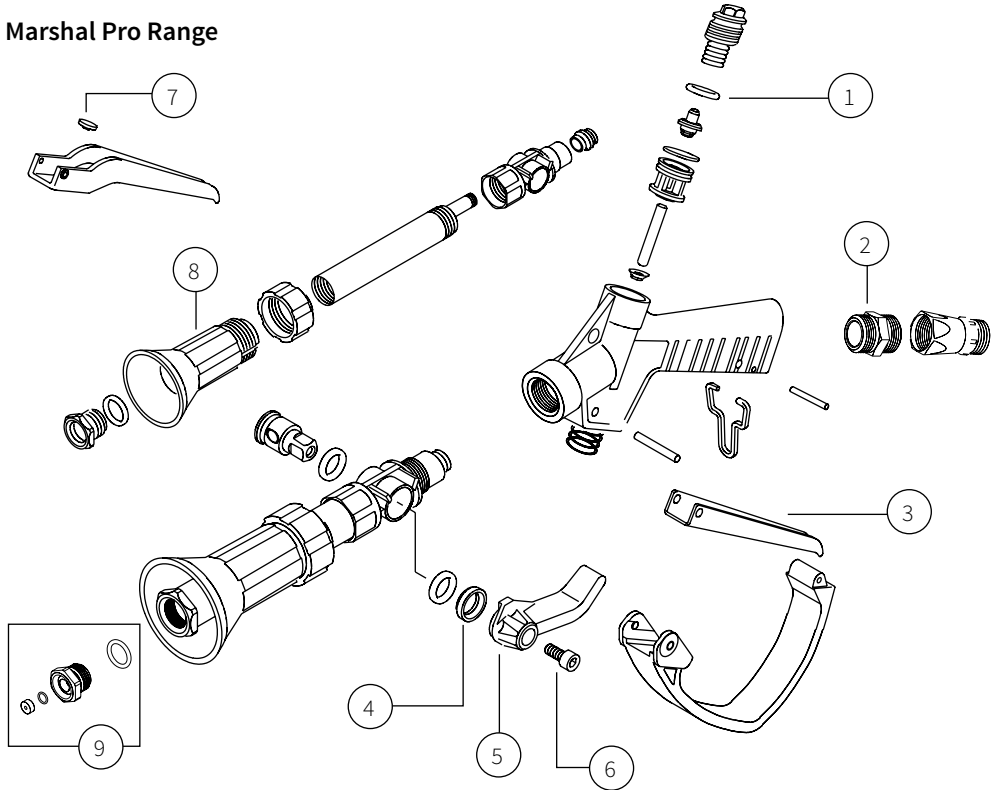

#	Part No.	Description
1	CRP2360236	O-Ring 121
2	CRP1626095	½" BSP Ring Nut
3	CRP239024	Metal Trigger (only suits Turbo 400 guns)
4	CRP26150614	O-Ring (orange lever)
5	CRP269026	Regulator Trigger
6	CRP26190220	Screw for orange lever
7	CRP2980140	Insert 8x4.8
8	CPLP102C	Plastic Shroud only

#	Part No.	Description
	CPLK102R	Complete Repair Kit for Turbo 400 Spray Gun
	CLPK102S	M30 Seals Kit
	CLPK102V	Viton Seals Kit
9	CPLP102N15 / 23 / 35	1.5mm / 2.3mm / 3.5mm Nozzle Kits

PISTOL GRIP SPRAY GUN | AHG104

Buddy® Marshal Pro Range

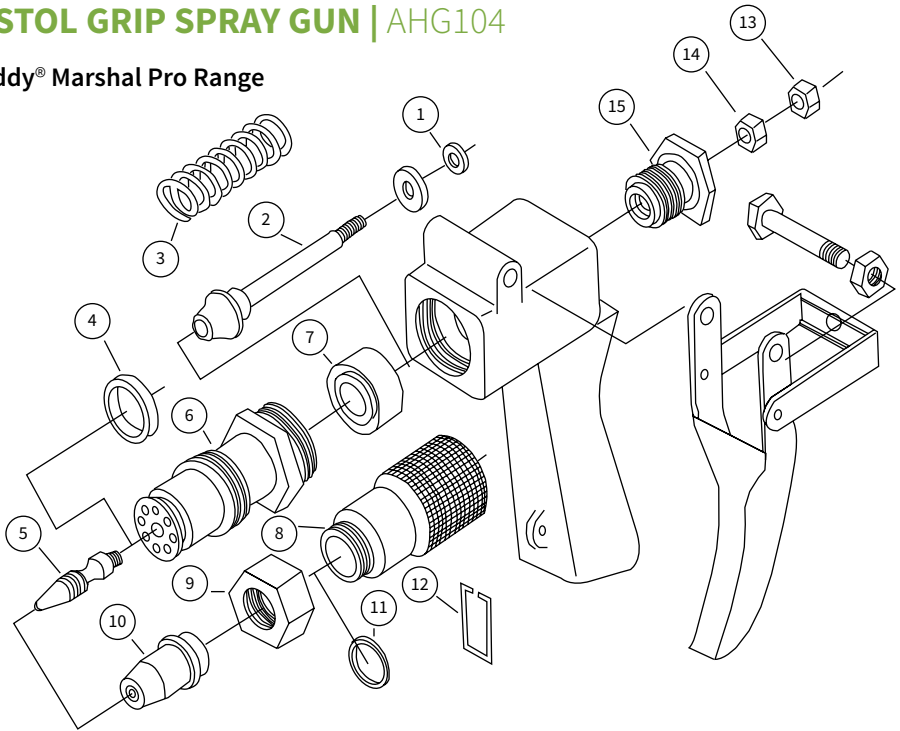

#	Part no.	Description
1 *		O Ring - Rubber
2 *		Valve Shaft - Brass with Chrome Plated
3	CPLD104Z05	Stainless Steel Spring
4 *		Gasket - Rubber
5 *		Pressure Axle - Brass
6	CPLD104Z08	Adjustable Shaft - Brass
7 *	CPLD104Z09	Gasket - Rubber
8	CPLD104Z10	Adjustable Bush - Brass
9	CPLD104Z11	Nut - Brass
10	CPLP104N [nozzle size]	Nozzle (nozzle size: 1mm, 1.5, 2, 2.5, 3, 3.5, 4, 6)
11 *	CPLD104Z13	O Ring - Rubber
12	CPLD104Z14	Fixed Ring
13	CPLD104Z18	Nut
14	CPLD104Z19	Nut
15	CPLD104Z20	Plug Nut
# *	CPLK04R	* All items with star included in repair kit.

WARRANTY

WARRANTY POLICIES AND PROCEDURES

The following warranty is the only warranty applicable to RAPID SPRAY products, and to the maximum extent permitted by law, overrides any other conditions or warranties Expressed or implied on RAPID SPRAY products.

Other than legislative obligations to the contrary, RAPID SPRAY will not be liable for and incidental or consequential damages arising from the ownership or use of a product. No person, including any dealer or representative of RAPID SPRAY is authorized to make any representation or warranty on behalf of RAPID SPRAY in addition or inconsistent with these provisions. Purchasers to whom these provisions apply agree to hold RAPID SPRAY not liable for claims by their customers in excess of the obligations of RAPID SPRAY expressly set forth herein.

NOTE: All tank and spray systems must have their warranty activated by returning warranty card located at the end of this document or registering online within 21 days of purchase by the end user.

THE WARRANTY

All products sold by RAPID SPRAY are guaranteed to be free from defect in materials workmanship or manufacture for a period of 12 months from the initial date of purchase, excepting the following exclusions;

Any parts/products found by RAPID SPRAY to be defective, either in material or workmanship will be replaced or repaired within this period, at no cost to the initial purchaser if following conditions are met:

- The item has been operated in accordance with all instructions and warnings provided
- Item is still owned and operated by the original purchaser - proof of purchase is required to obtain warranty



See <https://www.rapidspray.net/resources/warranty-registration> to register your Marshal Pro for warranty.



WWW.JAS-ANZ.ORG/REGISTER

The following things are expressly excluded from the above warranty.

ABUSE	Failure as a result of neglect, such as improper operation. Lack of maintenance or continued operation after discovery of a defect that leads to further damage
ALTERATIONS	Any unauthorized alteration, modification, attachments or unauthorized repair to equipment.
CLEAN-UP TIME	RAPID SPRAY does not pay for cleaning of products, parts or accessories or work area before or after the warranty repair.
DAMAGE	Damages or machine/component failure caused by carelessness/recklessness or accidental damage, improper operation, excessive speed, inappropriate storage or transportation.
ENVIRONMENTAL CONDITIONS & APPLICATION	Deteriorated or failed components such as o-rings, diaphragms, hoses, seals and connections damaged by corrosive chemicals, dirt and sand, excessive heat, moisture or other environmental impacts. Warranty determination on these type of failures will be made by RAPID SPRAY, only after inspection of the failed component.
INABILITY UNSUITABILITY	In no event shall RAPID SPRAY be liable to any person for indirect or consequential damages or for injury or commercial loss resulting from any use or inability to use any RAPID SPRAY product.
MAINTENANCE	Component failure due to failure to perform maintenance services such as, oil and grease changes/top-ups, failure to clean tanks, pumps filters, nozzles and spray lines. Failure to tighten or replace loose or missing bolts, nuts, fittings, shields and covers.
NON-GENUINE PARTS	Use of parts other than RAPID SPRAY parts for repair of warranted items will automatically negate any warranty. Warranted components must be replaced with genuine parts.

This page has been left blank intentionally.

Rapid Spray

35 Enterprise Cres, Singleton NSW 2330
PO BOX 3119 Singleton NSW 2330

Call us on 1800 011 000 or
visit www.rapidspray.net

WARRANTY REGISTRATION

You can register online at www.rapidspray.net/resources/warranty-registration or complete all the details below and post this form back to:

Rapid Spray, PO Box 3119, Singleton NSW 2330

Model Serial No

Purchased From
(Dealer Name & Town)

Purchaser's Name

Purchaser's Address
.....

Purchaser's Phone Number

Email Address:

Disclaimer: If you don't want us to keep you informed of new products, please tick the following circle:

To help us help you further, please complete the following:

Purchaser's Age

- Up to 25
- 25 - 40
- 41 - 55
- Over 55

Principal Usage

- Commercial farm
- Hobby farm
- Industrial
- Other.....
- Town council
- Hire company
- Home

What influenced you to purchase a Rapid Spray product?

- Received Catalogue
- Newspaper advertisement
- Magazine advertisement
- Dealer recommendation
- Friends recommendation
- Better features than competitor product
- Quality & reliability
- Price
- Past experience with Rapid Spray products
- Other.....

What other Rapid Spray products do you use?

- Spray tanks
- Cartage tanks
- Diesel tanks
- Fire fighting
- Boom sprayers
- Bertolini pumps & controllers
- Inter knapsacks | Compression sprayers
- Other.....



Call us on 1800 011 000 or
visit www.rapidspray.net

Rapid Spray

35 Enterprise Cres, Singleton NSW 2330
PO BOX 3119 Singleton NSW 2330

Telephone: 1800 011 000

Facsimile: 02 6571 2951

