



MARSHAL PLUS

OPERATORS HANDBOOK



MARSHAL PLUS
BUDDY MARSHAL PLUS

250L / 400L



CONTENTS

- 01** Introduction & Models
- 02** Warnings
- 03** Product Risk Assessment
- 04** Troubleshooting
- 05** Operation
- 06** Mixing & Filling
- 07** Calibration Guides
- 08** Spraying
- 10** Buddy Smart Reel Operation
- 12** Cleaning & Maintenance
- 14** Unit Identification Diagram
- 15** Marshal Tank Parts Breakdown
- 16** Pump, Motor & Reel Parts Breakdown
- 18** Turbo 400 Spray Gun Parts Breakdown
- 19** Warranty
- 21** Warranty Registration



INTRODUCTION

Thank you for your purchase of a Rapid Spray Marshal Plus, the built for purpose compact UTV sprayer. Complete and ready to mount to your vehicle or UTV* sprayer, enjoy your new Marshal Plus sprayer!

MODELS

Please note your unit may not have all the parts or accessories listed in this handbook.

This handbook covers the following models (including any custom variations):

MARSHAL PLUS RANGE

BUDDY MARSHAL PLUS RANGE



SU0250AL0120H
SU0250AL0120H3
SU0250AL0120H5

SU0400BL0120H

SU0250AL0120R5
SU0250AL0120R18

SU0400BL0120R5
SU0400BL0120R18

DISCLAIMER: In line with our policy of continuous improvement, the weights, dimensions and design may change slightly from what is shown in this operators handbook.

***WARNING:** Always obey vehicle and UTV/ATV manufacturer instructions regarding loading and operation. Please check weight restrictions. Serious death or injury can occur from improper usage. Rapid Spray accepts no liability for the unsafe operation of this unit.

WARNINGS

Read all warnings below and obey any instruction stickers or warnings on the spray unit. Failure to do so may result in serious bodily harm or death.

1. When mounting to any vehicle, ensure that you have read the Vehicle Owner's Manual and that you comply with all the weight restrictions as specified by the vehicle manufacturer, as overloading can cause injury or death. Remember that one litre of water weighs one kilogram. Ensure equipment is secure during transport.
2. To ensure your own safety and that of your employees or colleagues (if applicable), you must comply with all relevant environmental, work place health and safety legislation and codes of practice.
3. You must be in good mental health to operate this sprayer and not be under the influence of alcohol or any drugs that could impair your vision, physical strength, dexterity, judgment or other mental capacity.
4. Improper or careless use of this sprayer can cause serious injury. Minors should never be allowed to use this sprayer. This sprayer should not be used when bystanders or animals are in the area. This sprayer should never be used while children are in the area.
5. Before spraying, check the electrical and fuel systems for damage and deterioration. Replace parts as necessary. Do not modify the equipment or use any attachments other than those specified by the manufacturer.
6. Select and wear appropriate Personal Protective Equipment (PPE) in accordance with the label of the product you intend on using and your own safe work practices. PPE must still be worn while decontaminating your sprayer. Any accidental spills on the skin must be immediately be washed with clean water and soap.
7. Turn off the engine before filling the chemical tank. Spray during the morning or evening when it is cool. Intense sunlight will condense chemicals and may cause damage. Care should be taken when spraying in windy conditions as spray drift may contaminate the air and may affect the operator or damage adjacent non-target vegetation.
8. Spray only in well ventilated areas to keep away from flames or cigarettes. Keep all hoses and equipment away from the hot engine to avoid fire hazards.
9. Do not eat, drink or smoke while spraying to avoid ingestion of chemicals. Do not carry or store lunch boxes or other food and drink with spraying equipment.
10. Once the spraying operation has been completed, decontaminate the spray tank and spray accessories. Store any remaining chemicals in a safe place in a sealed container. Dispose of tank rinsing in compliance with the current environmental, work place health and safety regulations.
11. Never leave the sprayer unattended without turning off the engine and relieving the line pressure, and flushing the sprayer of any harmful chemicals.
12. Carry out maintenance as per the recommendations. Ensure that the unit is cool and securely stabilised on a level surface before commencing maintenance.

PRODUCT RISK ASSESSMENT

TASK	HAZARDS	RISK	CONTROL MEASURES
Partially fill the tank with water, start the motor and test the spray unit.	Manual handling; slips, trips or falls; petrol fumes; fingers jammed	Medium	Concentrate on tasks, follow safe manual handling techniques: don't lift on your own if > 20kg, bend knees, keep back straight; keep fingers clear; keep unit at least 8m away from overhead power-lines; fire extinguisher nearby; follow warning stickers on tanks; wear PPE for petrol and fumes (mask and gloves)
Check weather and ground conditions and select the appropriate PPE to suit the chemicals to be used.	Manual handling; slips, trips or falls.	Low	Put on PPE as per the chemical requirements in the Material Safety Data Sheet (MSDS) - coveralls, gloves and respirator; follow safe manual handling techniques: don't lift on your own if > 20kg, bend knees and keep back straight
Mix chemicals and fill spray tank units	As above; spray drift, chemical spillage, emission of vapours or flammability: weather; untrained visitors.	Medium	As above; user trained in the state's chemical mixing and administration course e.g. Chem Cert; follow the relevant Environment Protection Authority requirements, fire extinguisher present; keep visitors away from the job unless wearing full PPE
Use spray unit	As above; loss of load; work in heat & cold; noise; exceed load limit of vehicle; hose entanglement; terrain and slopes	High	As above; wear clothes to suit heat and cold; wear hearing protection if pump noise > 85 dBA; follow manufacturer's safe operation instructions for the vehicle and spray unit; don't overload - water weighs 1kg per 1L; secure load to vehicle; hose tidy
Clean up, maintenance and storage	As above	Low	As above; continue to wear PPE for clean-up, store tank in dry, well ventilated area
Buddy Smart Reel®			See Buddy Smart Reel® Operators Handbook
Pump / Motor			See pump / motor Operators Handbook

TROUBLESHOOTING

CONDITION	CAUSE	REMEDY
Pump will not prime	<ol style="list-style-type: none"> 1. Insufficient motor RPM 2. Air leak on suction plumbing 3. Blocked/ restricted intake hose 4. Filter cap disengaged 5. Filter gasket damaged / missing 	<ol style="list-style-type: none"> 1. Increase motor RPM until pump primes 2. Tighten/ replace fittings and hose clamps. Verify suction hoses are in good condition. 3. Remove blockage from suction line, ensure line is not kinked. 4. Lock filter cap into position. 5. Replace filter gasket.
Pressure drops / fluctuates during standard operation	<ol style="list-style-type: none"> 1. Restriction on suction line 2. Pump sucking air 3. Plugged filter 4. Damaged regulator 	<ol style="list-style-type: none"> 1. Inspect tank and suction lines and remove restriction 2. Tighten fittings 3. Remove and clean filter mesh and housing 4. Remove regulator stem and inspect for broken parts / pieces
Pressure gauge not registering	<ol style="list-style-type: none"> 1. Plugged with debris 	<ol style="list-style-type: none"> 1. Unthread, check and clean pressure gauge
Hand gun loses pressure	<ol style="list-style-type: none"> 1. Debris in hose or nozzle 2. Pump losing prime 3. Pump pressure dropping / fluctuating 	<ol style="list-style-type: none"> 1. Unthread nozzle tip and clean 2. See 'Remedy' for 'Pump will not prime' 3. See 'Remedy' for 'Pressure drops / fluctuates during standard operation'
Buddy Smart Reel®		See Buddy Smart Reel® Operators Handbook
Pump / Motor		See pump / motor Operator's Handbook

! WARNING !

Always obey vehicle and UTV/ATV manufacturer instructions regarding loading and operation. Please check weight restrictions. Serious death or injury can occur from improper usage. Rapid Spray accepts no liability for the unsafe operation of this unit.

OPERATION

PRE-START UP

1. Familiarise yourself with the unit (see page 14).
2. Inspect the unit for any broken or damaged components - replace damaged/broken components as necessary.
3. Familiarise yourself with the HONDA motor instruction manual (supplied with unit), and ensure you follow all warnings and instructions contained within it.

WARNING: the motor is shipped without oil or fuel - before operation, fill the motor with the correct oil and fuel as advised in the HONDA motor instruction manual.

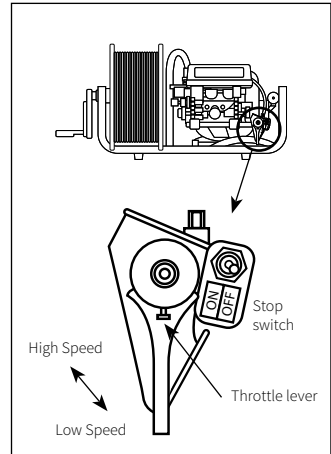

START UP

1. Confirm tank contents contains chemical/water.
2. Push the priming pump on the carburettor several times until fuel begins to flow.
3. Set the throttle lever to the 'LOW' position. Set the choke lever to the 'CLOSE' position when the engine is cold.
4. Turn the pressure regulating knob anti-clockwise to the 'BYPASS' ("0" pressure) position.
5. While holding the sprayer steady, grip the recoil starter handle and pull quickly.
6. While checking the engine status after start-up, return the choke lever to the 'OPEN' position.

Allow engine to warm-up for 2-3 minutes before commencing spraying operation.

OPERATION - Manipulating the pressure regulating valve

Turn the pressure regulating knob clockwise to increase pressure, and anti-clockwise to decrease pressure. The sprayer requires less power when the regulating valve is set to low pressure or the flow requirements are low. Running the engine with the throttle lever fully open will result in unnecessary noise and increased fuel consumption. It is recommended to operate with the throttle lever at a medium setting.

WARNING: Be aware, operating at too low a throttle setting will allow clutch to slip.

MIXING & FILLING

The following steps are given as a guide to mixing and filling your Marshal Plus sprayer.

1. Read the product label and follow the instructions carefully, taking special note with regard to the order in which the products are added to the tank.

CAUTION: Mixing sites must be well away from watercourses and other environmental sensitive areas. Children and animals must be kept away.

2. Measure out the correct quantity of chemical using clean measuring jugs used only for this purpose.
3. Half fill the sprayer with clean water.
4. Commence agitation of the Marshal Plus with following steps:
 - Pressure control lever must be in the 'by-pass' position. Turn regulator valve knob in an anti-clockwise direction to reduce pressure to 'O' bar.
 - Add the chemicals as measured correctly to the spray tank while still agitating.
 - Rinse out the measuring jug and pour all rinsing's into the spray tank. Safely dispose of empty containers in compliance with current regulations.
 - Top up the tank with water to the required level; ensure that the tank is not over-filled and the outside is clean and dry before handling.
 - Your Marshal Plus has now been correctly filled and the product thoroughly mixed. Spraying can now commence.
5. To commence spraying, move the pressure control lever clockwise to the 'press' position, close the spray gun or boom and turn the adjustment knob in an anti-clockwise direction until your desired pressure has been reached. Open the spray gun or boom and start spraying.



CALIBRATION GUIDE

Accurate calibration is an essential element of any spraying function as it ensure that the pesticide is applied at the rate as recommended by the product manufacturer. Application in excess of the recommended rate is prohibited, can damage crops and is uneconomical. View the products packaging for recommended spraying applications.

Calibration must always be carried out:

- Spraying for the first time with new spray equipment
- At the beginning of each season
- After changes of nozzle tips, spraying pressure or speed
- After every 100 hectares of spraying
- Changes in pesticide

NOTE: When calibrating a sprayer, appropriate personal protective wear should be worn.

STEP-BY-STEP CALIBRATION GUIDE		EXAMPLE
Read the label. Find the following:	Spray Volume (VOLUME) Product Dose Spray QUALITY	200L / hectare 50L / hectare Medium
Measure: Time / 100m	Measure time to spray 100m in seconds over land similar to that which will be sprayed.	41.9 seconds
Calculate: SPEED	Speed (km/h) = 360 divided by time (seconds)	$\frac{360}{41.9} = 8.6\text{km/h}$
Measure nozzle SPACING	Distance between each nozzle	0.5m
Measure: L/min OUTPUT	Output = VOLUME x SPEED x SPACE ÷ 600 (L/min) (L/hectare) (km/h) (metre)	$200 \times 8.6 \times 0.5 \div 600$ Output = 1.433L/min
Choose NOZZLE	Refer to nozzle manufacturers data charts or other sources and select the size and type of nozzle that will product the calculated OUTPUT and spray QUALITY	
Now, check the calibration on the sprayer.		
Check Nozzle OUTPUT	With water, check outputs of 4 or more nozzles using a calibrated jug or flow meter. Check all nozzles are aligned correctly and spray patterns are good.	Average Output = 41.9L/minute
Calibrate Sprayer	SPRAY VOLUME = OUTPUT x 600 ÷ SPEED ÷ SPACE (L/min) (km/H) (metre)	$1.4 \times 600 \div 8.6 \div 0.5 = 195$

If, as in the example, the nozzle output and therefore, spray volume, is less than the recommended figures, increase the pressure and repeat calibration until target spray volume is reached.

SPRAYING

For effective spraying, ensure you have taken the following factors into account.

1. Before commencing spraying, plan the work effectively to reduce potential contamination.
2. Do not spray if the operator, bystanders, watercourses or any non-target vegetation appears to be in danger from spray drift contamination.
3. Work Rates
 - Speed of operation
 - Water points or nurse tanks
 - Rate of travel
 - Swath width
 - Spray volume applied
4. Wind and drift
 - Wind speed
 - Wind direction
 - Airspeed at boom height
 - Wind direction and drift is controlled by;
 - » Reducing nozzle height
 - » Reducing pressure and using larger nozzles
 - » Fit low-drift nozzles producing larger droplets

NOTE: Avoid spraying on still warm days or during the night as convection currents may cause drift in unpredictable directions. Optimum wind speeds are between 3km/h to 7km/h.

5. Field Work (for use with boom attachment)
 - Swath marking and spraying
 - Mark out to ensure proper pass matching - use flags, foam markers or tram-lines
 - Where large obstacles exist in the middle of an area to be sprayed, mark out and spray the area like a separate headland.
 - The perimeter of the field should be sprayed first. The width of two swaths will give adequate turning space at the ends of spray runs.
 - Never spray while turning.
6. Maintain constant speed when spraying. Should you need to increase your spraying speed, larger delivery nozzles must be fitted. Re-calibrate as required.

NOTES





BUDDY SMART REEL® (WHERE FITTED)

Please read the Buddy Smart Reel® Operators Handbook for full instructions, parts and maintenance instructions.





Please note your Marshal Plus sprayer may not require the following instructions. Only applicable to Buddy® Marshal Plus sprayer units.

OPERATION

1. Switch power to the Reel and confirm that the display shows .
2. Pull the hose out to the required length for spraying.
3. To retract hose at maximum speed, press the  button on the MyPace remote.
4. To retract the hose at a slower speed, press the  button on the MyPace remote. Always maintain a slight pull on the hose as it is rewinding to ensure a consistent layout of the hose on the spool.
5. Please note that the reel must not be connected to a pressure reading that is greater than 40Bar.
6. Connect the spray gun to the fitting at the end of the hose.
7. In case of a misplaced remote the button on the switch panel will operate as a manual fast rewind.

SETTING/CHANGING CUSTOM SPEED MYPACE REMOTE

The MyPace function allows a custom rewind speed to be set and stored. It can easily be re-calibrated as often as needed to suit changing conditions in terrain, weather or each operator's personal preference.

1. Pull the hose out to at least 20m.
2. Press both   buttons on the MyPace handheld remote.
3. The Buddy® hose reel will begin to rewind at its minimum speed. The speed will gradually increase while both buttons remain pressed.
4. When the desired speed is reached, release the  button and the reel will continue at that set speed. (If both buttons are held for approximately 20 seconds the reel will reach maximum speed).
5. Releasing both buttons will cause the custom speed to be stored in the memory of the remote.
6. When the  button is pressed the reel will operate at the set speed.
7. The custom speed can be reset as often as needed by starting back at step 2.





PAIRING MYPACE REMOTE TO BUDDY SMART REEL®

The MyPace handheld remote should be delivered already paired to the Buddy Hose Reel. If several reels have been purchased and it is not clear as to which remote is paired to which reel or if the remote has been replaced, the remote can be re-paired to the reel at any time.

How to pair the MyPace remote

1. Stand within reach of the Buddy Reel switch panel.
2. Ensure the reel is powered and switched on.
3. Remove the batteries from the remote.
4. Press both buttons on the remote and insert the batteries while holding the buttons.
5. Green lights will flash slowly on the remote and the display on the switch panel on the reel will slowly flash **PA**.
6. Within 10 seconds, press the manual rewind button on the reel switch panel.
7. Successful pairing will be acknowledged by the display on switch panel flashing PA fast for a few seconds then return to a steady **□**. (The green light on the remote may continue to flash slowly for a few seconds then stop).
8. After the green light on the remote stops flashing, press either button to confirm that the reel is responding.

READING LED LIGHTS & SWITCH PANEL CODES

 Slow flash	Unit in pairing mode	 Very fast flash	Battery low and fast rewind pressed
 Very fast flash	Fast rewind button pressed	 Fast flash	Battery low and slow rewind pressed
 Fast flash	Slow rewind button pressed		

Your Buddy Smart Reel® is equipped with a display to indicate its current status. During operation of your reel you may observe the following messages on the display.

- **□** = Reel powered correctly, on standby, ready to operate
- **PA** = Reel has not been paired to a remote
- **PA** = Reel is in pairing mode
- **LL** = Supply voltage to reel is too low
- **FR** = Reel is rewinding at the fast setting
- **SL** = Reel is rewinding at the slow speed

CLEANING & MAINTENANCE

After use, the sprayer must be thoroughly decontaminated, inside and outside. Decontaminating the tank, including pumps, hoses and hand lance, avoids damage to crops from harmful spray residues and prevents sprayer corrosion and abrasion. As a guide, follow the decontamination procedure below:

1. After spraying, rinse all liquid out of the tank.
NOTE: When flushing the sprayer, pay attention to where the chemical will run. Always clean in an area that will not contaminate water sources or crops.
2. After draining the tank, rinse the inside by spraying clean water with a pressure washer.
3. Turn the pump off and fill the tank with clean water and a recommended cleaning liquid.
NOTE: to ensure any pesticide residue is removed from the tank, let the water and cleaning solution sit for 8 hours.
4. The suction filter mounted on the sprayer frame must be cleaned regularly. Unscrew the filter cover and remove the filter screen and gasket. Soak in clean water, brushing with a nozzle brush. Ensure gasket is in position when re-assembling.
5. The filter basket strainer is removed by lifting it out of the filler ring. Clean the basket strainer the same way as the suction filter. Replace the basket strainer by exerting a quick downward push ensuring the strainer has seated correctly.
6. Nozzles, nozzle filters, nozzle caps and gaskets should be cleaned by soaking in water, brushing with a nozzle brush and allowed to dry. Never blow through the nozzles with your mouth or use wire or pins to clear blockages. When re-assembling, ensure that the nozzle cap gasket is correctly positioned.
7. Ensuring all nozzles, filters etc. are back in place, flush the water through the entire system; turn the pump on and spray the clean water through the booms and hand lance.

Mounted sprayers tend to be unstable when removed from the tractor. Make sure they are safely chocked before leaving them.

When storing the sprayer, ensure that it is clean and dry. Keep in a well ventilated place.

CLEANING & MAINTENANCE cont.

PUMP MAINTENANCE

Check pump Operators Handbook for maintenance schedule.

- Check to make sure that all screws are tightened and that no parts are missing.
- Check to make sure there are no loose connections on hoses, nozzle, lance or valves.
- Thoroughly clean the nozzle and filter. Take the cap off the filter housing and remove filter screen for cleaning. Ensure filter screen is properly located before screwing cap back on.

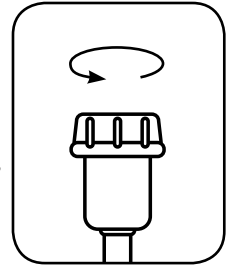

LUBRICATION

- There are two grease cups (marked with “←” on the back of the pump)
- Always ensure grease cups are filled with general purpose grease. Screw grease cups 2-3 turns every 2hrs of operation.

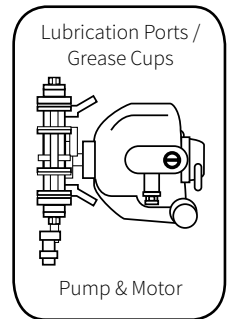

INSPECT THE ENGINE

Check engine Operators Handbook for maintenance schedule and further instructions.

- Check to make sure there are no loose or missing screws in any part of the engine.
- Clean the air filter regularly - particularly if working in a dusty environment.
- Clean and adjust the spark plug as necessary.
- Clean the cooling fan, air intake opening and parts around the muffler.
- Check the engine oil and change it as necessary.
- Inspect the fuel line filter, check for fuel leaks.

LONG TERM CLEANING & STORAGE

- When storing the sprayer, ensure that it is clean and dry and kept in a ventilated place where it will not be subject to freezing temperatures. Frozen water may crack metal components and void warranty.
- Completely drain any water from the pump.
- Pull the recoil started handle slowly until there is no resistance.
- After removing the fuel from the tank, push the priming pump until fuel in the line runs out. Remove fuel from the tank once more.
- Check the engine oil and change if necessary.
- Set the throttle lever in the low speed position.

IDENTIFICATION DIAGRAM

Position and part may change from unit to unit.

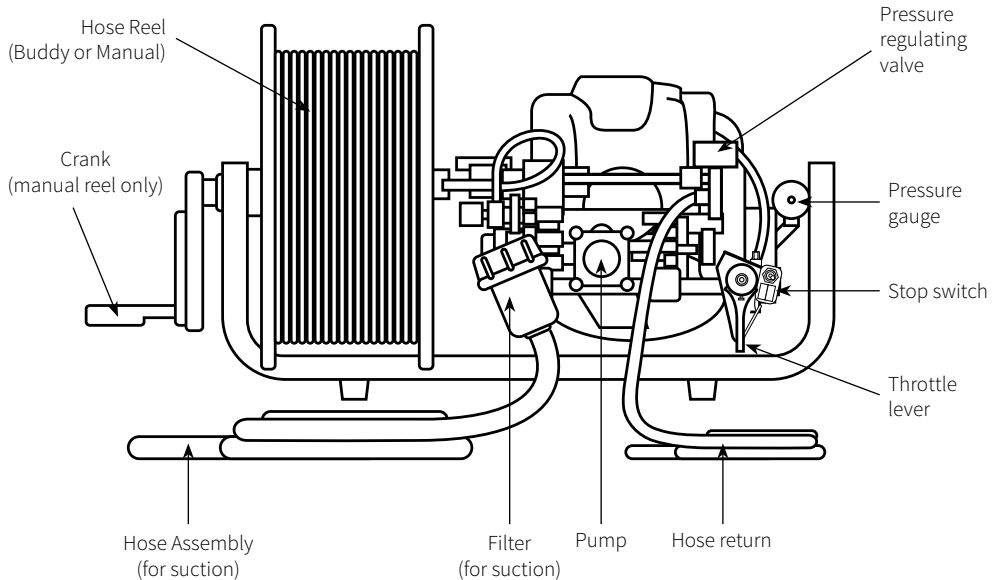
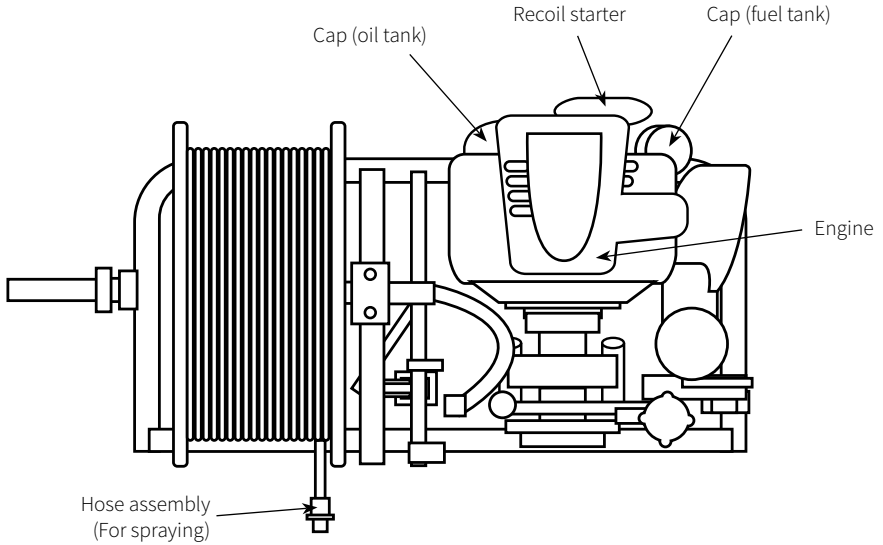

MARSHAL TANK PARTS BREAKDOWN

250L MARSHAL TANK

910 (L) x 730 (W) x 620 (H)

400L MARSHAL TANK

1480 (L) x 755 (W) x 660 (H)

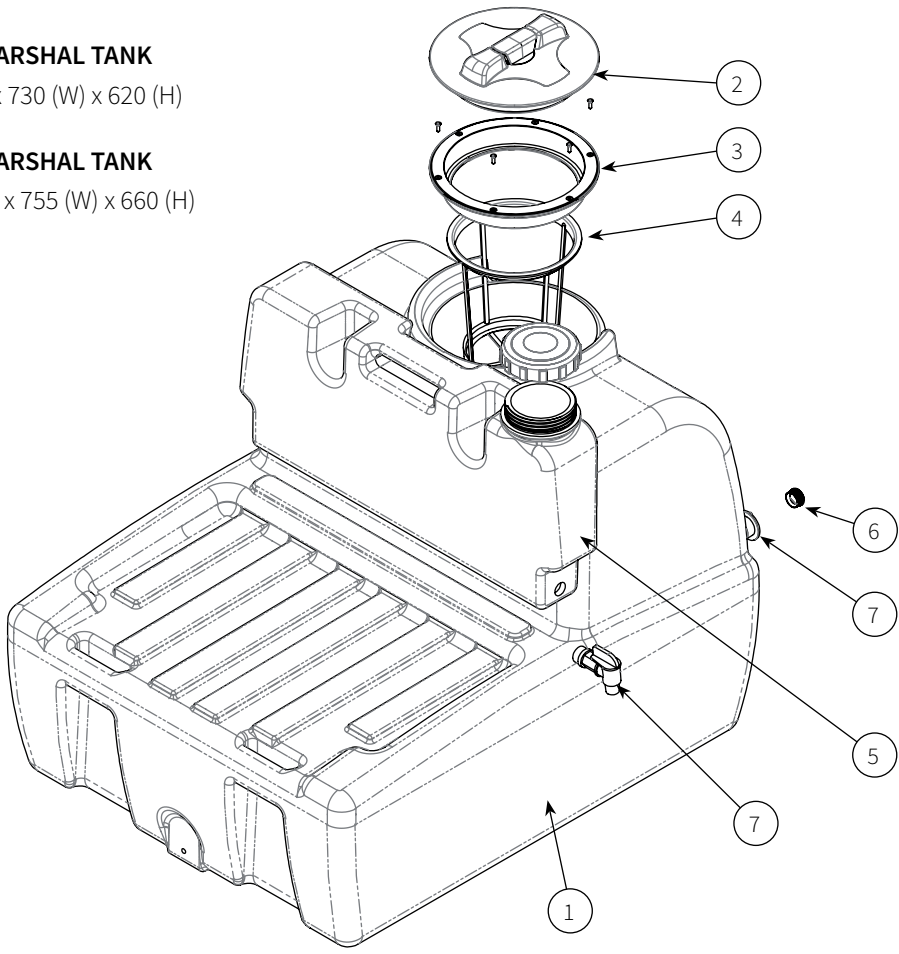

#	Part No.	Qty	Description
1	AMPTC00200ATT / 400BTT	1	200 / 400L Marshal Tank
2, 3, 4	ARLP250VSR	1	255mm Screw Lid
5	AMAXPM010BK	1	10L Rinse Tank (only Marshal Plus units)
6,7	CFNB20M	1	3/4" poly Drain Bun & Seal
8	CFVTB20M	1	3/4 20mm Bibcock (only Marshal Plus units)

PUMP, MOTOR & REEL PARTS BREAKDOWN

Marshal Plus unit (manual reel) diagram for illustrative purposes.

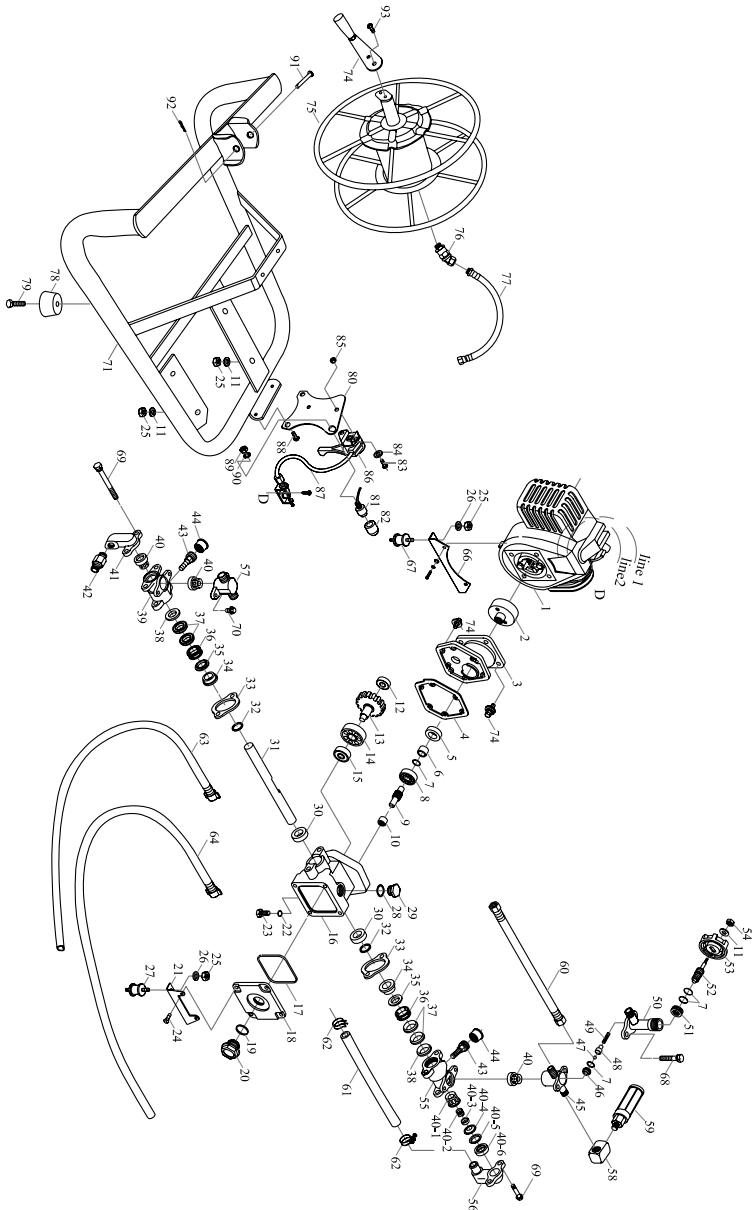

#	Part No.	Qty	Description	#	Part No.	Qty	Description
1		1	Honda GX35 Engine	44	CPUPP044	1	Grease cup
2	CPUPP002	1	Clutch Drum	45	CPUPP045	1	Outlet Manifold
3	CPUPP003	1	Housing Housing	46	CPUPP046	1	Regulator seat
4	CPUPP004	1	Housing Gasket	47	CPUPP047	1	Regulator ball
5	CPUPP005	1	Oil Seal	48	CPUPP048	1	Regulator ball cup
6		1	Steel Spacer	49	CPUPP049	1	Regulator spring
7	CPUPP007	4	9x13 O-Ring	50	CPUPP050	1	Regulator valve housing
8	CPUP008	1	Bearing HK1010	51	CPUPP051	1	Regulator housing nut
9		1	Shaft	52	CPUPP052	1	Regulator valve screw
10	CPUPP014	1	Bearing 6203	53	CPUPP053	1	Regulator knob
15	CPUPP015	1	Bearing 6200	54	CPUPP054	1	M6 Nyloc Nut
16	CPUPP016	1	Crank Case 18mm	55	CPUPP055	1	Cylinder head RIGHT
17	CPUPP017	1	O-Ring G60	56	CPUPP056	6	Suction manifold RIGHT
18	CPUPP018	1	Crank Case Cover	57		4	Outlet manifold LEFT
19	CPUPP019	1	O-Ring G25	58		8	Elbow ¼ NPT
20	CPUPP020	1	Oil Glass	59	CPUPP059	2	Pressure gauge
21		1	Pump Stand	60	CPUPP060	1	Pressure manifold hose
22	CPUPP022	1	O-Ring	61	CPUPP061	1	Suction manifold hose
23	CPUPP023	1	Draining Plug	62	CPUPP062	2	Hose clamp
24		6	M6x12 Screw	63	CPUPP063	1	Bypass hose
25		4	M6 Nut	64		2	Suction hose
26		4	M6 Spring Washer	66		1	Engine stand
27	CPUPP027	2	Rubber Mount	67	CPUPP067	2	Rubber mount
28	CPUPP028	1	O-Ring	68		2	M6x45 Screw
29	CPUPP029	1	Oil Filler Cap	69		2	M6x75 Screw
30	CPUPP030	2	Oil Seal	70		2	M6x12 Screw
31	CPUPP031	1	18mm Piston	71	CPUPP071	1	Steel Frame
32	CPUPP032	1	O-Ring	74		1	Screw M6x16
33		2	Fixed Plate	75	CPUPP075	1	Hose reel spool
34	CPUPP034	2	Adjusting ring	76	CPUPP076	1	Hose reel swivel
35	CPUPP035	2	Grease Ring	77	CPUPP077	1	Hose reel whip hose
36	CPUPP036	2	V-packing upper seal	78	CPUPP078	4	Rubber foot
37	CPUPP037	4	V-packing	79		4	M8x25 Screw
38	CPUPP038	1	Packing seat	80		1	Throttle mounting plate
39	CPUPP039	1	Cylinder Head LEFT	81		1	Hill switch
40	CPUPP040	1	Valve Assembly	82		1	Rubber sheath
40-1		1	Valve Nut	83		2	¾"x¾"L Screw
40-2		1	Valve Spring	84		2	¾" Washer
40-3		1	Valve Plug	85		2	¾" Nut
40-4		4	Valve Seat	86		1	Throttle
40-5		1	Valve Ring	87		1	Throttle cable comp
40-6		1	Valve Packing	88		2	Screw
41	CPUPP041	1	Suction manifold LEFT	89		2	Washer
42		2	Connector Nipple	90		2	Nut
43	CPUPP043	1	Grease cup	122	CPUPP0122	1	Ball valve & tee piece

TURBO 400 SPRAY GUN | AHG102

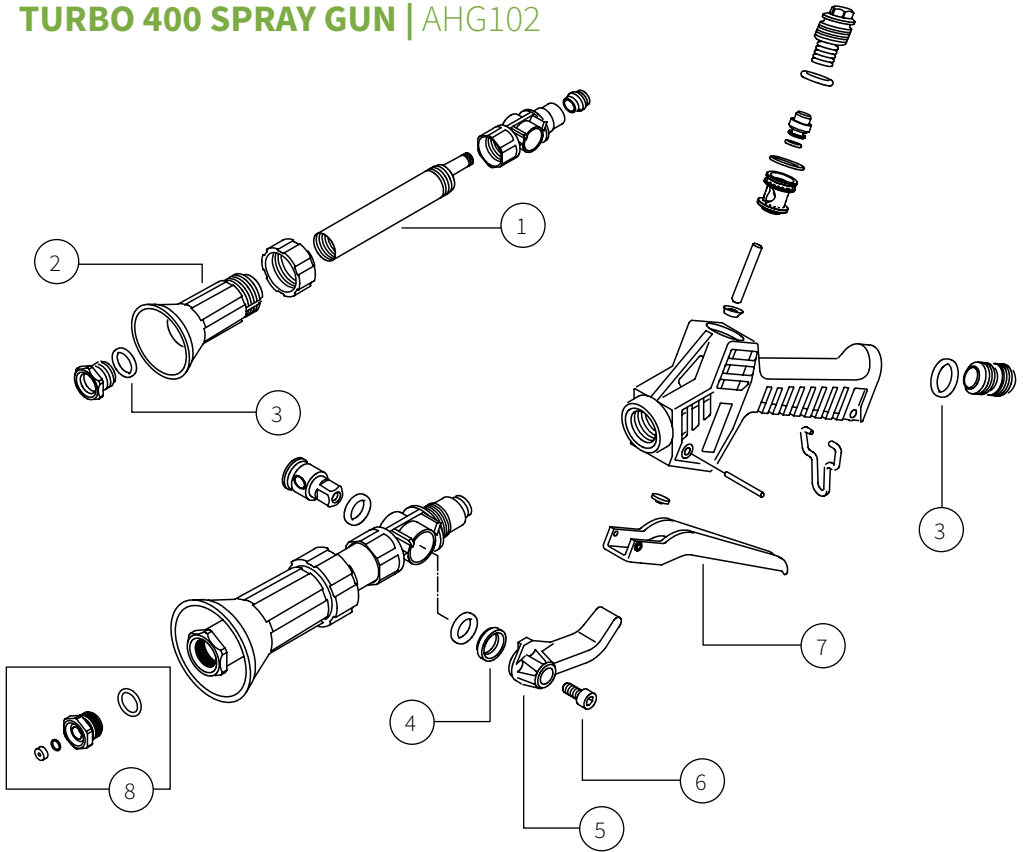

#	Part No.	Description
1	CRP26170369	Spline
2	CPLP102C	Plastic shroud
3	CRP2360234	O-Ring 121
4	CRP265150614	O-Ring (Orange Lever)
5	CRP269026	Regulator trigger
6	CRP26190220	Screw Orange Lever
7	CPLK102G	Orange trigger & seat

#	Part No.	Description
	CPLK102R	Complete Repair Kit for Turbo 400 Spray Gun
	CLPK102S	M30 Seals Kit
	CLPK102V	Viton Seals Kit
8	CPLP102N15 / 23 / 35	1.5mm / 2.3mm / 3.5mm Nozzle Kits

WARRANTY

WARRANTY POLICIES AND PROCEDURES

The following warranty is the only warranty applicable to RAPID SPRAY products, and to the maximum extent permitted by law, overrides any other conditions or warranties Expressed or implied on RAPID SPRAY products.

Other than legislative obligations to the contrary, RAPID SPRAY will not be liable for and incidental or consequential damages arising from the ownership or use of a product. No person, including any dealer or representative of RAPID SPRAY is authorized to make any representation or warranty on behalf of RAPID SPRAY in addition or inconsistent with these provisions. Purchasers to whom these provisions apply agree to hold RAPID SPRAY not liable for claims by their customers in excess of the obligations of RAPID SPRAY expressly set forth herein.

NOTE: All tank and spray systems must have their warranty activated by returning warranty card located at the end of this document or registering online within 21 days of purchase by the end user.

THE WARRANTY

All products sold by RAPID SPRAY are guaranteed to be free from defect in materials workmanship or manufacture for a period of 12 months from the initial date of purchase, excepting the following exclusions;

Any parts/products found by RAPID SPRAY to be defective, either in material or workmanship will be replaced or repaired within this period, at no cost to the initial purchaser if following conditions are met:

- The item has been operated in accordance with all instructions and warnings provided
- Item is still owned and operated by the original purchaser - proof of purchase is required to obtain warranty



See <https://www.rapidspray.net/resources/warranty-registration> to register your Marshal Plus for warranty.



WWW.JAS-ANZ.ORG/REGISTER

The following things are expressly excluded from the above warranty.

ABUSE	Failure as a result of neglect, such as improper operation. Lack of maintenance or continued operation after discovery of a defect that leads to further damage
ALTERATIONS	Any unauthorized alteration, modification, attachments or unauthorized repair to equipment.
CLEAN-UP TIME	RAPID SPRAY does not pay for cleaning of products, parts or accessories or work area before or after the warranty repair.
DAMAGE	Damages or machine/component failure caused by carelessness/recklessness or accidental damage, improper operation, excessive speed, inappropriate storage or transportation.
ENVIRONMENTAL CONDITIONS & APPLICATION	Deteriorated or failed components such as o-rings, diaphragms, hoses, seals and connections damaged by corrosive chemicals, dirt and sand, excessive heat, moisture or other environmental impacts. Warranty determination on these type of failures will be made by RAPID SPRAY, only after inspection of the failed component.
INABILITY UNSUITABILITY	In no event shall RAPID SPRAY be liable to any person for indirect or consequential damages or for injury or commercial loss resulting from any use or inability to use any RAPID SPRAY product.
MAINTENANCE	Component failure due to failure to perform maintenance services such as, oil and grease changes/top-ups, failure to clean tanks, pumps filters, nozzles and spray lines. Failure to tighten or replace loose or missing bolts, nuts, fittings, shields and covers.
NON-GENUINE PARTS	Use of parts other than RAPID SPRAY parts for repair of warranted items will automatically negate any warranty. Warranted components must be replaced with genuine parts.

WARRANTY REGISTRATION

You can register online at www.rapidspray.net/resources/warranty-registration or complete all the details below and post this form back to:

Rapid Spray, PO Box 3119, Singleton NSW 2330

Model Serial No

Purchased From
(Dealer Name & Town)

Purchaser's Name

Purchaser's Address

Purchaser's Phone Number

Email Address:

Disclaimer: If you don't want us to keep you informed of new products, please tick the following circle:

To help us help you further, please complete the following:

Purchaser's Age

- Up to 25
- 25 - 40
- 41 - 55
- Over 55

Principal Usage

- Commercial farm
- Hobby farm
- Industrial
- Other.....
- Town council
- Hire company
- Home

What influenced you to purchase a Rapid Spray product?

- Received Catalogue
- Newspaper advertisement
- Magazine advertisement
- Dealer recommendation
- Friends recommendation
- Better features than competitor product
- Quality & reliability
- Price
- Past experience with Rapid Spray products
- Other.....

What other Rapid Spray products do you use?

- Hand / Backpack Sprayers
- Cartage / Spray tanks
- Diesel refuelling units / tanks
- Fire fighting
- UTV / Field sprayers
- Pumps, motors and controllers
- Chapin / Jacto sprayers
- Other.....



Call us on 1800 011 000 or
visit www.rapidspray.net

35 Enterprise Cres, Singleton NSW 2330
PO BOX 3119 Singleton NSW 2330

Telephone: 1800 011 000
Facsimile: 02 6571 2951

Rapid Spray Liquid Management Systems

