

Spray Tanks Operator's Handbook



Contents

01	Introduction
02	Product Risk Assessment
03	Warning Notices
03	Liquid Surge
04	Footing Details For Tanks With A Sump
05	Sample Frame Details For Tanks With A Sump
06	Tank Fitting Locations For Tanks With A Sump
08	Warranty Agreement
11	Warranty Registration

Introduction

Congratulations on your purchase of a Rapid Spray, Spray Tank. Ideal for the transport of liquids where complete drainage and cleaning is critical. Rapid Spray pin mount spray tanks are specifically designed for chemical and liquid fertiliser spraying with integral sump for minimising waste and complete drainage.

Warnings

1. When mounting to any vehicle ensure that you have read the Vehicle Owner's Manual and that you comply with all the weight restrictions as specified by the vehicle manufacturer, as overloading can cause injury or death
2. To ensure your own safety and that of your employees if applicable you must comply with all relevant environmental, work place health and safety legislation and codes of practice
3. Ensure tank is firmly secured in an appropriate manner. Where applicable tank mounting may need to be designed / approved by an engineer
4. Care should be taken at all times, particularly when operating on rough or steep terrain Drivers should be aware of liquid surge at all times
5. WHS requirements for working at heights must be complied with as applicable
6. Personal Protection Equipment must be worn if required
7. Improper or careless use of this tank can cause serious injury or death. Minors should never be allowed to use this tank
8. Tank is a confined space. Ensure compliance with WHS requirements if entering tank
9. You must be in good mental health to operate this tank and not be under the influence of alcohol or any drugs that could impair your vision, physical strength, dexterity, judgement, or other mental capacity

Product Risk Assessment

Task	Hazards	Risk	Control Measures
1. Ensure tank mounted correctly on vehicle and do not overload vehicle, partially fill the tank with water & test the tank or pumping system, if necessary, before use.	Load not secured; overload vehicle; manual handling; slips; trips or falls; finger jammed; overhead powerlines-electricity; leaks tank is a confined space.	Medium	Read decals on the tank; follow safe manual handling techniques: - don't lift on your own if > 20kg, bend knees & keep back straight; keep fingers clear; keep tank at least 8m away from overhead powerlines; keep water away from electrical sources; make sure tank mounted securely to comply with relevant codes of practice and transport authority requirements; don't exceed vehicle load limit; follow state legislation & AS 2865:2001 Confined Space; trailer chassis mount frame if used on roads.
2. Check weather & ground conditions & select the appropriate PPE to suit the chemicals to be used-if applicable.	Manual handling; slips, trips or falls; ground instability.	Low	Put on PPE, as required from the Material Safety Data Sheet – coveralls, gloves, safety footwear, glasses & respirator; follow safe manual handling techniques as above; drive cautiously to suit conditions.
3. Mix chemicals & fill tanks with chemicals and or water. Check that transport vehicles is safe before use, i.e. Where applicable: - wheel nuts, tyres pressure, bearings, to hitch, has been serviced, etc.	As above for 1 & 2; spray drift, chemical spillage, emission of vapours or flammability; weather; untrained visitors.	Medium	As above 1 & 2; user trained in the state's chemical mixing & administration course e.g. Chem Cert; follow the relevant Environment Protection Authority requirements, fire extinguisher present; keep visitors away from the job unless wearing full PPE.
4. Use tank from a vehicle – take into account the sway of the water & fluid in the tank when driving.	As above; loss of load; work in heat & cold; noise; exceed load limit of vehicle; strap breakage; horse entanglement; exhaust fumes; terrain & slopes.	High	As above 1 & 2; wear clothes to suit heat & cold; wear hearing protection if pump noise > 85 dBA; follow manufacturer's safe operation instructions for the vehicle & the pump/spray unit; don't overload-water weighs 1kg per 1 litre; secure load to vehicle; hose tidy.
5. Clean up, maintenance & storage.	As above.	Low	As above; continue to wear PPE for clean up; store tank in a dry, well-ventilated area.

Warning Notices

Copy of stickers attached to tank are shown below. Please ensure that these instructions are followed. Safety decals should be kept clean and legible at all times. If any decals are missing or unreadable, they should be replaced by ordering new decals from your Rapid Spray dealer. Use the part numbers shown. Replacement decals are supplied F.O.C.



CODE: **CKA008**



CODE: **CKA020**

On the following pages is a recommended frame design for mounting our tanks.

WARRANTY IS CONDITIONAL ON TANK BEING CORRECTLY MOUNTED.

Liquid Surge

Rapid Spray strongly recommends the use of the Rapid Ball Baffle system to control liquid surge when in transit. Please call 1800 011 000 for details.



Ball Baffles® – ARB355
Large Ball Baffle ø355mm

1 Ball Baffle per 40L of tank capacity



Ball Baffles® – ARB195
Small Ball Baffle ø195mm

1 Ball Baffle per 7L of tank capacity

Footing Details For Tanks With A Sump

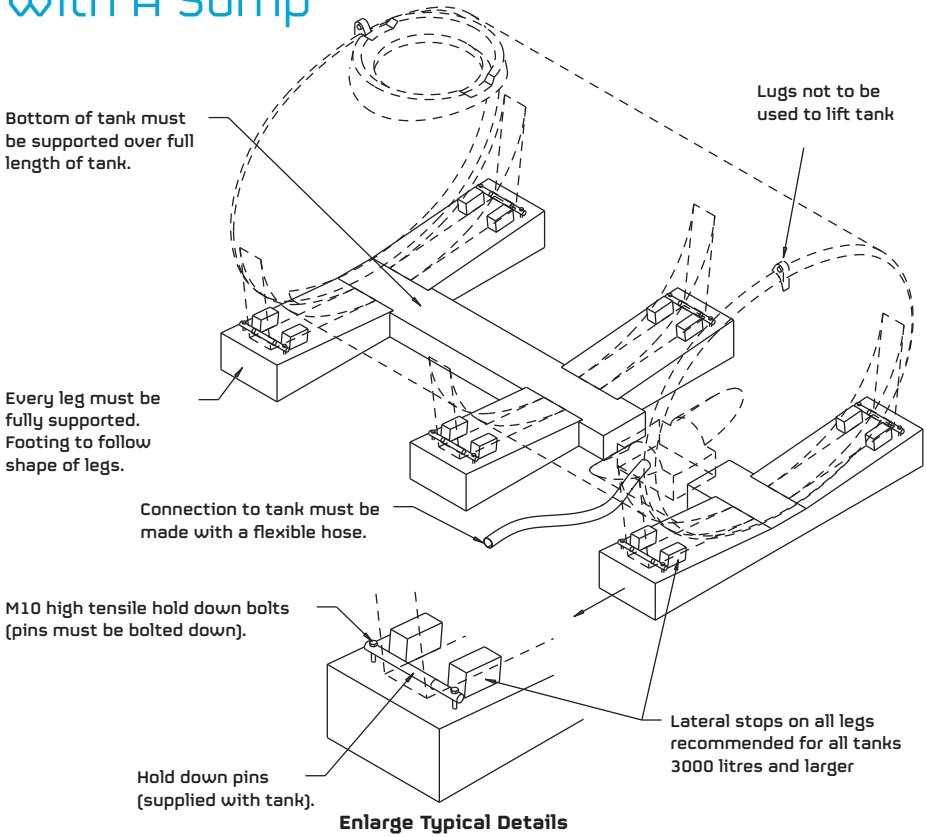

Cutaway shows full drain sump

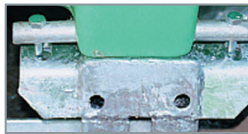

Outside view of Pin



End view shows sump clearance



Cutaway of Pin

***Tanks not mounted in accordance with our specifications may void warranty.**

Sample Frame Details For Tank With Sump

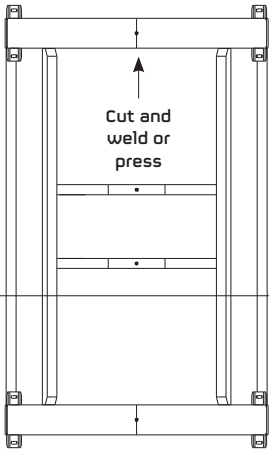
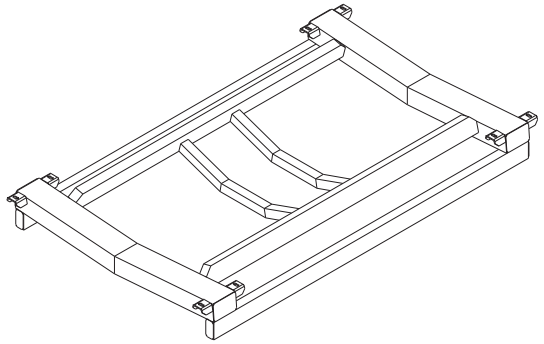
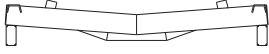

Material: Mild steel to AS3679.1-250/300 or equivalent
Surface treatment: Remove all sharp edges. All welds to be 5mm cont. fillet or full penetration butt welds

A

Enlarged section A

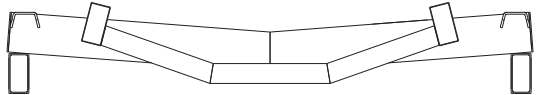

Tank Fitting Locations For Tanks With A Sump

* Placing fittings in locations other than those recommended may result in failure or damage and void warranty. Only use approved brass and poly fittings.

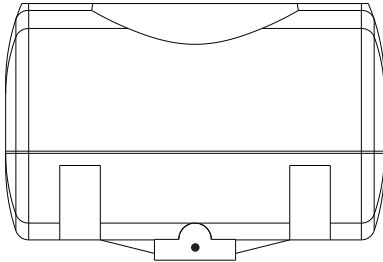
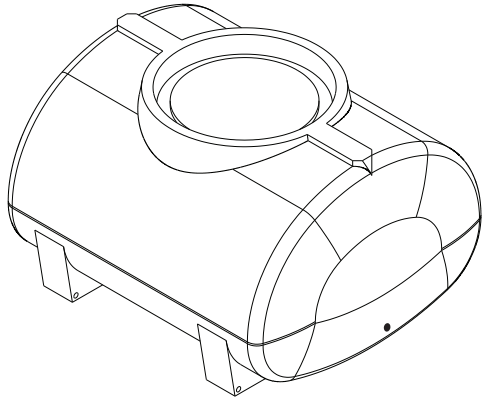
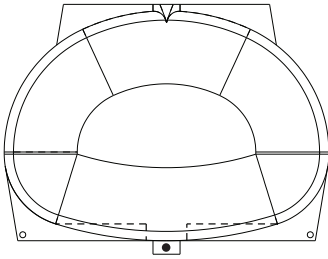

● Recommended Tank Fitting Locations for Tanks with a Sump

Fitting Suggestion

All spray tanks require a steel mounting frame to give sumps clearance for access

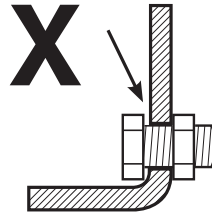
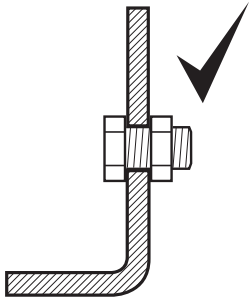

For tank fitting in side of sump

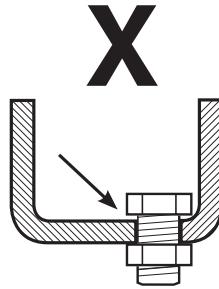
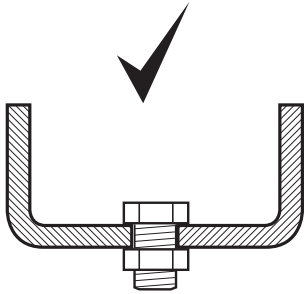

For tank fitting in bottom of sump

Warranty Agreement

Rapid Spray provides a quality tank and water cartage/spray system for the use of our clients.

To ensure continuous and quality use, we undertake this Warranty Agreement to enable trouble free and Quality Assured service of our tanks and spray systems.

Please read and understand all documents in the Warranty Pack adhered to your tank.

This pack contains:

1. Operators Handbook
2. Mounting Plan and Directions
3. Frame Drawings
4. Documents to be Returned (including Pre-paid envelope)
5. Quality Assurance checklist

On purchasing a Rapid Spray tank or system, customers are requested to read all documents carefully and ensure they understand the operation system, ensure correct mounting and restraint to the specifications and drawings provided, prior to use.

Step 1. Take ALL documents and plans from plastic sleeve and read them

Step 2. Complete Warranty Registration Form and return to Rapid Spray, PO BOX 3119 SINGLETON NSW 2330 (attach copy of receipt to Warranty Form) to initiate registration,

Step 3. Purchase or manufacture frame/mounting system in conjunction with Rapid Spray's design/plan

Step 4. Mount and secure tank in compliance with specifications as supplied by Rapid Spray

Step 5. Ensure any fittings from tank to motor/sprays or outlets are flexible and NOT rigid

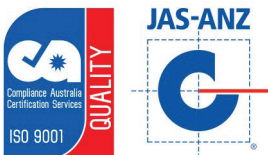

WWW.JAS-ANZ.ORG/REGISTER

.....

In all cases warranty will Include:

- Workmanship of tank (manufacture)
- Quality of raw materials and fittings
- Integrity and workmanship of frame/skid – if purchased from Rapid Spray
- Guarantee on NEW Tank for a pro-rata period of 10 years (for original purchaser)
- Mounting instructions are adhered to and proof of purchase is provided

To avoid doubt – Warranty does not cover the following:

- Tank mishandling, misuse, or faults caused by failure to follow mounting advice or routine maintenance
- Unauthorised alterations or changes to tanks (including welding, cutting, or mounting)
- Damage from use of rigid/fixed outlets to pumps or other fittings
- Damage from wear or tear
- Incorrect placing and securing of pumps or tanks
- Freight or costs associated with repairs associated with any of the above
- Costs associated with dismantling, installation or re-installation of the tank or frame



The following things are expressly excluded from the above warranty.

Abuse	Failure as a result of neglect, such as improper operation. Lack of maintenance or continued operation after discovery of a defect that leads to further damage
Alterations	Any unauthorized alteration, modification, attachments or unauthorized repair to equipment.
Clean-Up Time	RAPID SPRAY does not pay for cleaning of products, parts or accessories or work area before or after the warranty repair.
Damage	Damages or machine/component failure caused by carelessness/recklessness or accidental damage, improper operation, excessive speed, inappropriate storage or transportation.
Environmental Conditions & Application	Deteriorated or failed components such as o-rings, diaphragms, hoses, seals and connections damaged by corrosive chemicals, dirt and sand, excessive heat, moisture or other environmental impacts. Warranty determination on these type of failures will be made by RAPID SPRAY, only after inspection of the failed component.
Inability Unsuitability	In no event shall RAPID SPRAY be liable to any person for indirect or consequential damages or for injury or commercial loss resulting from any use or inability to use any RAPID SPRAY product.
Maintenance	Component failure due to failure to perform maintenance services such as, oil and grease changes/top-ups, failure to clean tanks, pumps filters, nozzles and spray lines. Failure to tighten or replace loose or missing bolts, nuts, fittings, shields and covers.
Non-Genuine Parts	Use of parts other than RAPID SPRAY parts for repair of warranted items will automatically negate any warranty. Warranted components must be replaced with genuine parts.



Registering your warranty couldn't be easier!

Warranty Registration

You can register online at www.rapidspray.net/warranty-registration or complete all the details below and post this form back to:

Rapid Spray, PO Box 3119, Singleton NSW 2330

Model Serial No

Purchased From
(Dealer Name & Town)

Purchaser's Name

Purchaser's Address
.....

Purchaser's Phone Number

Disclaimer: If you don't want us to keep you informed of new products, please tick this circle

To help us help you further, please complete the following:

Purchaser's Age

- Up to 25
- 25 – 40
- 41 – 55
- Over 55

Principle Usage

- Commercial farm
- Hobby farm
- Industrial
- Other
- Town council
- Hire company
- Home

What influenced you to purchase a Rapid Spray product?

- Catalogue received
- Newspaper advertisement
- Magazine advertisement
- Dealer recommendation
- Friend's recommendation
- Better features than other competitors
- Quality & reliability
- Price
- Past experience with Rapid Spray products
- Website

What other Rapid Spray products do you use?

- Spray tanks
- Cartage tanks
- Diesel tanks
- Fire fighters
- Boom sprayers
- Bertolini pumps & controllers
- Inter knapsacks | Compression sprayers
- Other





Call us on 1800 011 000 or
visit www.rapidspray.net

35 Enterprise Cres, Singleton NSW 2330
PO Box 3119 Singleton NSW 2330
www.rapidspray.net

Telephone 1800 011 000
Facsimile 02 6571 2951

Rapid Spray Liquid Management Systems

