



FIRE MARSHAL

OPERATORS HANDBOOK



FIRE MARSHAL
FIRE MARSHAL PLUS

250L / 325L



CONTENTS

- 01** Introduction & Models
- 02** Warnings
- 03** Product Risk Assessment
- 04** Troubleshooting
- 05** Operation
 - 05** Before Beginning Operation
 - 05** Operation
- 06** Honda GX35 Engine
- 12** Kawashima Fire Pump
- 15** Cleaning & Maintenance
- 17** Fire Marshal Breakdowns & Spare Parts
 - 18** Marshal Tank
 - 19** Poly Fire Fighting Hose Reel
- 20** Warranty
- 23** Warranty Registration



INTRODUCTION

Thank you for your purchase of a Rapid Spray Fire Marshal. The Fire Marshal 250 and Fire Marshal 325 is an Australian Made compact fire fighter great for back burning, tree watering, and stock water supply - all from the back of your UTV.

MODELS

Please note your unit may not have all the parts or accessories listed in this handbook. **This handbook covers the following models** (including any custom variations):

FIRE MARSHAL



Example Codes:
SF0200ALZ
SF0325LZ

FIRE MARSHAL PLUS



Example Codes:
SF0200ALZH4
SF0325LZH4

DISCLAIMER: In line with our policy of continuous improvement, the weights, dimensions and design may change slightly from what is shown in this operators handbook.

***WARNING:** Always obey vehicle and UTV/ATV manufacturer instructions regarding loading and operation. Please check weight restrictions. Serious death or injury can occur from improper usage. Rapid Spray accepts no liability for the unsafe operation of this unit.

WARNINGS

Read all warnings below and obey any instruction stickers or warnings on the unit. Failure to do so may result in serious bodily harm or death.

1. When mounting to any vehicle, ensure that you have read the Vehicle Owner's Manual and that you comply with all the weight restrictions as specified by the vehicle manufacturer, as overloading can cause injury or death. Remember that one litre of water weighs one kilogram. Ensure equipment is secure during transport.
2. To ensure your own safety and that of your employees or colleagues (if applicable) you must comply with all relevant environmental, work place health and safety legislation and codes of practice. In particular be aware of Rural Fire Service guidelines for safety when fighting fires or backburning.
3. You must be in good mental health to operate this unit and not be under the influence of alcohol or any drugs that could impair your vision, physical strength, dexterity, judgment or other mental capacity.
4. Improper or careless use of this unit can cause serious injury. Minors should never be allowed to use this unit. This unit should not be used when bystanders or animals are in the area. This unit should never be used while children are in the area.
5. Before using, check the electrical and fuel systems for damage and deterioration. Replace parts as necessary. Do not modify the equipment or use any attachments other than those specified by the manufacturer.
6. Select and wear appropriate Personal Protective Equipment (PPE) in accordance with the label of the product you intend on using and your own safe work practices.
7. Never leave the sprayer unattended without turning off the engine and relieving the line pressure.
8. All operators must be trained in safe use of this unit.
9. Carry out maintenance as per the recommendations. Ensure that the unit is cool and securely stabilised on a level surface before commencing maintenance.

PRODUCT RISK ASSESSMENT

TASK	HAZARDS	RISK	CONTROL MEASURES
Partially fill the tank with water, start the motor and test the fire fighting unit.	Manual handling; slips, trips or falls; petrol fumes; fingers jammed	Medium	Concentrate on tasks, follow safe manual handling techniques: don't lift on your own if > 20kg, bend knees, keep back straight; keep fingers clear; keep unit at least 8m away from overhead power-lines; fire extinguisher nearby; follow warning stickers on tanks; wear PPE for petrol and fumes (mask and gloves)
Check weather and ground conditions and select the appropriate PPE to suit the chemicals to be used.	Manual handling; slips, trips or falls.	Low	Put on PPE as per the chemical requirements in the Material Safety Data Sheet (MSDS) - coveralls, gloves and respirator; follow safe manual handling techniques: don't lift on your own if > 20kg, bend knees and keep back straight
Mix chemicals (if applicable) and fill fire fighting unit	As above; spray drift, chemical spillage, emission of vapours or flammability; weather; untrained visitors.	Medium	As above; user trained in the state's chemical mixing and administration course e.g. Chem Cert; follow the relevant Environment Protection Authority requirements, fire extinguisher present; keep visitors away from the job unless wearing full PPE
Use fire fighter unit	As above; loss of load; heat and cold; noise; exceed load; limit of vehicle; hose entanglement; exhaust fumes; terrain and slopes; run over by unit	High	As above; wear clothes to suit heat and cold; wear hearing protection if pump noise > 85 dBa; follow manufacturer's safe operation instructions for the vehicle and spray unit; don't overload - water weighs 1kg per 1L; secure load to vehicle; hose tidy
Clean up, maintenance and storage	As above	Low	As above; continue to wear PPE for clean-up, store unit in a dry, well ventilated area
Pump / Motor			See pump / motor Operators Handbook

TROUBLESHOOTING

CONDITION	CAUSE	REMEDY
Pump will not prime / draw water	<ol style="list-style-type: none"> 1. Insufficient motor RPM 2. Air leak on suction plumbing 3. Blocked/ restricted intake hose 4. Filter cap disengaged 5. Filter gasket damaged / missing 	<ol style="list-style-type: none"> 1. Increase motor RPM until pump primes 2. Tighten/ replace fittings and hose clamps. Verify suction hoses are in good condition. 3. Remove blockage from suction line, ensure line is not kinked. 4. Lock filter cap into position. 5. Replace filter gasket.
Pumps runs but will not develop pressure	<ol style="list-style-type: none"> 1. Residue on pump valves 2. Worn regulator 	<ol style="list-style-type: none"> 1. Remove and clean pump valves 2. Install regulator service kit
Pressure drops / fluctuates during standard operation	<ol style="list-style-type: none"> 1. Restriction on suction line 2. Pump sucking air 3. Plugged filter 4. Damaged regulator 	<ol style="list-style-type: none"> 1. Inspect tank and suction lines and remove restriction 2. Tighten fittings 3. Remove and clean filter mesh and housing 4. Remove regulator stem and inspect for broken parts / pieces
Pressure gauge not registering	<ol style="list-style-type: none"> 1. Plugged with debris 	<ol style="list-style-type: none"> 1. Unthread, check and clean pressure gauge
Oil in pump or gearbox appears white and murky after operation	<ol style="list-style-type: none"> 1. Water or chemical has contaminated oil. 	<ol style="list-style-type: none"> 1. Check pump valves, seals and pump oil breather cap. Replace / fix if needed. 2. Replace oil if needed.
Hand gun loses pressure	<ol style="list-style-type: none"> 1. Debris in hose or nozzle 2. Pump losing prime 3. Pump pressure dropping / fluctuating 	<ol style="list-style-type: none"> 1. Unthread nozzle tip and clean 2. See 'Remedy' for 'Pump will not prime' 3. See 'Remedy' for 'Pressure drops / fluctuates during standard operation'
Pump / Motor		See pump / motor Operator's Handbook

OPERATION

BEFORE BEGINNING OPERATION

1. Check all hoses, connections and hose clamps to ensure that the unit has been delivered to you without transportation loss or damage.
2. Before attempting any fire fighting with your new unit, operate it to familiarise yourself with its features and capabilities and to ensure that your unit has arrived in a safe working condition. Please contact your dealer immediately should anything appear to have been damaged.
3. Load the unit onto the back of a vehicle and fasten the unit securely to the vehicle by strapping or bolting it down. Ensure that the straps do not interfere with any hoses or connections. Do not place the straps over the pump or engine. Keep hoses and straps away from hot engine, exhaust and exhaust fumes.
4. Familiarise yourself with the MOTOR and PUMP instruction / operators handbook (supplied with the unit) and ensure you follow all warnings and instructions contained within.

WARNING! Motor is shipped without oil or fuel. Before operation, fill the motor with the correct oil and fuel as advised in the MOTOR instruction / operators handbook.

OPERATION

1. Fill tank from appropriate water source. Open ball valve on suction hose at bottom of tank. Start motor and allow to warm up. Bypass valve is fitted to top of pump and should be adjusted to allow bypass for warm up period.
2. Unlock hose reel to allow hose to be pulled out. When using fire fighter adjust nozzle to desired spray pattern.
3. Increase engine speed and adjust bypass to achieve desired flow rates. When job is finished turn engine off, rewind hose onto reel and lock reel to prevent unwinding. Close ball valve on suction hose.
4. Please note this unit is designed for fire fighting and washdown or tree watering use and not for chemical spraying. Please consult the manufacturer for further information.

WARNING! Be sure the pump is filled with water before starting the engine as advised in the PUMP instruction / operators handbook.

HONDA GX35 ENGINE

Please read the Honda® Owners Manual for full safety, operation, parts and maintenance instructions. Always follow manufacturers directions.

SAFETY INFORMATION



- Understand the operation of all controls and learn how to stop the engine quickly in case of emergency. Make sure the operator receives adequate instruction before operating the equipment.
- Do not allow children to operate the engine. Keep children and pets away from the area of operation.
- Your engine's exhaust contains poisonous carbon monoxide. Do not run the engine without adequate ventilation, and never run the engine indoors.
- The engine and exhaust become very hot during the operation. Keep the engine at least 1 meter (3 feet) away from buildings and other equipment during operation. Keep flammable materials away, and do not place anything on the engine while it is running.

SAFETY MESSAGES

Your safety and the safety of others are very important. We have provided important safety messages in this manual and on the engine. Please read these messages carefully.

A safety message alerts you to potential hazards that could hurt you or others. Each safety message is preceded by a safety alert symbol  and one of these three words: DANGER, WARNING or CAUTION.

This signal words mean:

- | | |
|---|--|
|  DANGER | You WILL be KILLED or SERIOUSLY HURT if you don't follow instructions. |
|  WARNING | You CAN be KILLED or SERIOUSLY HURT if you don't follow instructions. |
|  CAUTION | You CAN be HURT if you don't follow instructions. |

You will also see other important messages that are preceded by the word NOTICE.

This word means:

- | | |
|---------------|--|
| NOTICE | Your engine, other property, or the environment can be damaged if you don't follow instructions. |
|---------------|--|

HONDA GX35 ENGINE CONT.

COMPONENT & CONTROL LOCATIONS

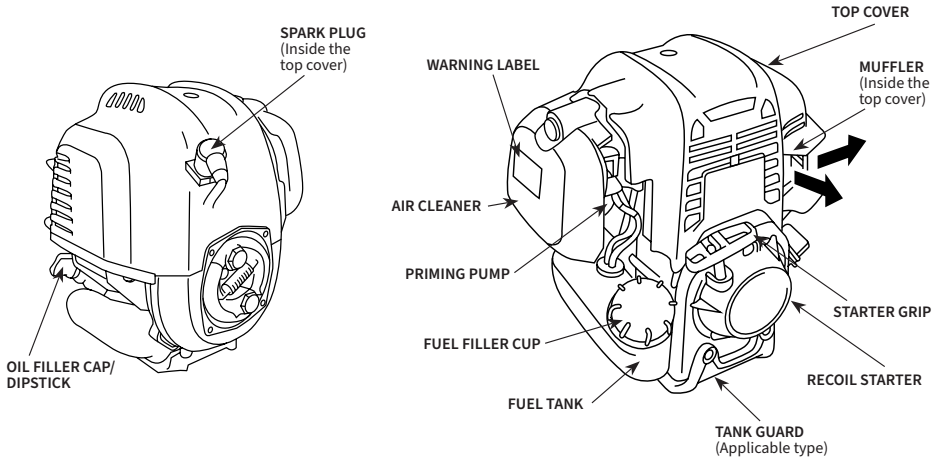

ENGINE CONTROLS:

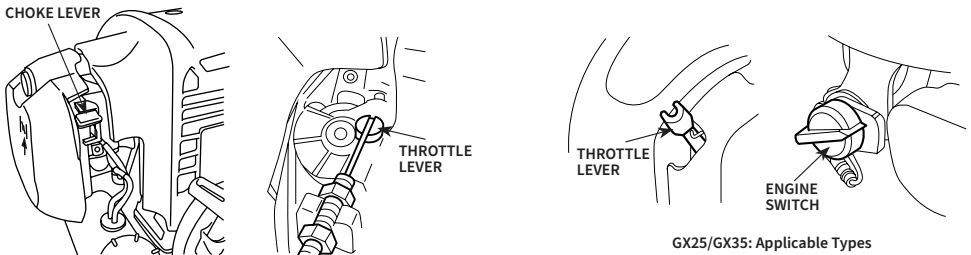

FEATURES

Centrifugal Clutch

The centrifugal clutch automatically engages and transmits power when engine speed is increased above approximately GX35: 4,200 min⁻¹(rpm). At idle speed, the clutch is disengaged.

NOTICE: Do not run the engine without mounting it on equipment that includes the centrifugal clutch drum and housing, or centrifugal force will cause the clutch shoes to contact and damage the engine case.

HONDA GX35 ENGINE CONT.

BEFORE OPERATION CHECKS

Is your engine ready to go?

For your safety, to ensure compliance with environmental regulations, and to maximize the service life of your equipment, it is very important to take a few moments before you operate the engine to check its condition. Be sure to take care of any problem you find, or have your servicing dealer correct it, before you operate the engine.

WARNING

Improperly maintaining this engine, or failure to correct a problem before operation can cause a malfunction in which you can be seriously hurt or killed.

Always perform a pre-operation inspection before each operation and correct any problem.

Before beginning your pre-operation checks, be sure the engine is level and the engine switch is in the OFF position.

Always check the following items before you start the engine:

Check the General Condition of the Engine

1. Look around and underneath the engine for signs of oil or gasoline leaks.
2. Remove any excessive dirt or debris, especially around the muffler and recoil starter.
3. Look for signs of damage.
4. Check that all shields and covers are in place, and all nuts, bolts and screws are tightened.

Check the Engine

1. Check the fuel level. Starting with a full tank will help eliminate or reduce operating interruptions for refuelling.
2. Check the engine oil level. Running the engine with a low oil level can cause engine damage.
3. Check the air filter elements. A dirty air filter element will restrict air flow to the carburetor, reducing engine performance.
4. Check the equipment powered by this engine.

Review the instructions provided with the equipment powered by this engine for any precautions and procedures that should be followed before engine startup.

HONDA GX35 ENGINE CONT.

SAFE OPERATING PRECAUTIONS

Before operating the engine for the first time, please review the SAFETY INFORMATION section and the BEFORE OPERATIONS CHECKS on previous cards.

For your safety, do not operate the engine in an enclosed area such as a garage. Your engine's exhaust contains poisonous carbon monoxide gas that can collect rapidly in an enclosed area and cause illness or death.

WARNING

Exhaust contains poisonous carbon monoxide gas that can build up to dangerous levels in closed areas. Breathing carbon monoxide can cause unconsciousness or death.

Never run the engine in a closed or even partly closed area where people may be present.

Review the instructions provided with the equipment powered by this engine for any safety precautions that should be observed with engine startup, shutdown or operation.

STARTING THE ENGINE

Refer to the instructions provided with the equipment for throttle lever and engine switch.

1. To start a cold engine, move the choke lever [1] to the CLOSED [A] position.
To restart a warm engine, leave the choke lever in the OPEN [B] position.

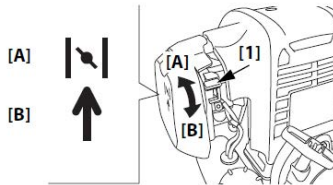

2. Press priming pump [2] several times until the priming pump is filled with fuel. Even if the priming pump is pressed too many times, the extra fuel will return to the fuel tank. If the priming pump is not pressed enough, the engine may not start.

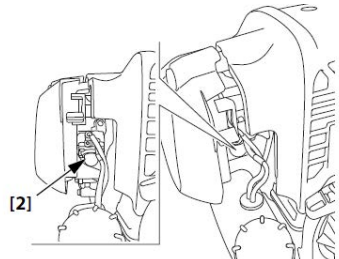

HONDA GX35 ENGINE CONT.

STARTING THE ENGINE cont.

3. Turn the engine switch [3] to the ON (I) [A] position.

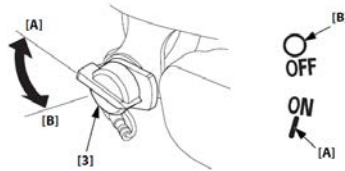

4. Pull the start grip [4] lightly until you feel resistance, then pull briskly in the direction of the arrow [5]. Return the starter grip gently.

Notice: Do not allow the starter grip to snap back against the engine. Return it gently to prevent damage to the starter.

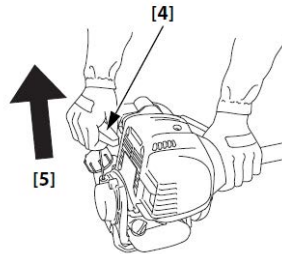

5. If the choke lever was moved to the CLOSED [A] position to start the engine, gradually move it to the OPEN [B] position as the engine warms up.

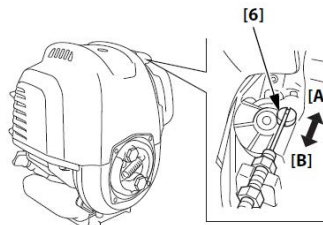

Hot Restart: If the engine is operated at higher ambient temperatures, then turned off and allowed to sit for a short time, it may not restart on the first pull.

If necessary, use the following procedure:

HONDA GX35 ENGINE CONT.

STARTING THE ENGINE cont.

IMPORTANT SAFETY PRECAUTION

Turn the engine switch to OFF position before performing the following procedure. This will prevent the engine from starting and running at maximum speed when the throttle is in the MAX speed position. If the engine starts with the throttle in the MAX speed position, the equipment can move forward rapidly or the trimmer attachment can spin at maximum speed. This may result in personal injury.

1. Turn the engine switch to OFF [O] [B] position.
2. Move the choke lever to the OPEN position
3. Hold the throttle level [6] on the equipment in the MAX [B] position.
4. Pull the starter grip 3 to 5 times.

Follow the STARTING THE ENGINE procedure and start the engine with the choke lever in the OPEN position.

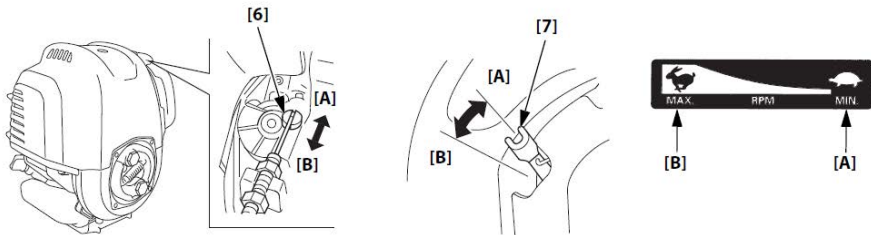

SETTING THE ENGINE SPEED

Position the throttle lever for desired engine speed.

STOPPING THE ENGINE

To stop the engine in an emergency, simply turn the engine switch to the OFF (O) position. Under normal conditions, use the following procedure.

1. Move the throttle lever to the MIN (🚗) [A] position.
2. Turn the engine switch to the OFF (O) position.

KAWASHIMA FIRE PUMP

Please read the Pump Owners Manual for full safety, operation, parts and maintenance instructions. Always follow manufacturers directions.

SAFETY INFORMATION

- Do not start the engine if the pump has no water.
- Place the pump on a firm and level surface to prevent the pump from overturning.
- Never pump flammable or corrosive liquids such as gasoline or acid.
- To avoid pump corrosion, never pump sea water, chemical medicinal liquids or caustic liquids - such as used oil, wine or polluted water.
- To prevent fire hazards and to provide adequate ventilation, keep the pump at least 1 meter (3 feet) away from building wall and other equipment during operation.
- Do not place flammable objects close to the pump.
- Children and pets must be kept away from the area of operation to reduce a possibility of burns from the hot engine components.

WATER HOSE INSTALLATION

1. Install the hose joints on the pump.
2. Connect the hoses on the joints with clamp.

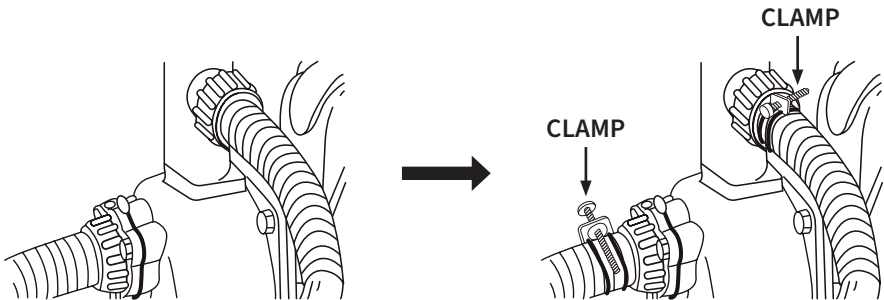

NOTE. When installing the joint to the pump, be sure the gasket is in place. Ensure that the hoses are securely installed or air lead will occur and water will not be drawn up.

KAWASHIMA FIRE PUMP CONT.

WATER HOSE INSTALLATION CONT.

3. Connect the strainer on the inlet hose end.

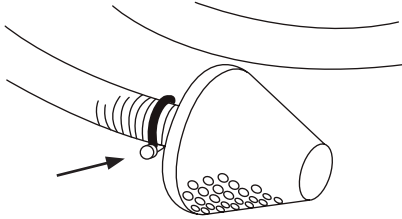

WARNING! Be sure the strainer is installed or pump damage will occur.

NOTE. Discharge port angle can be changed to 3 different directions. Adjust to your operating condition.

4. Submerge the suction hose strainer in the water
5. Remove self-suction plug and top up the pump with water. Make sure the water is at pump casing upper level. Add water as necessary

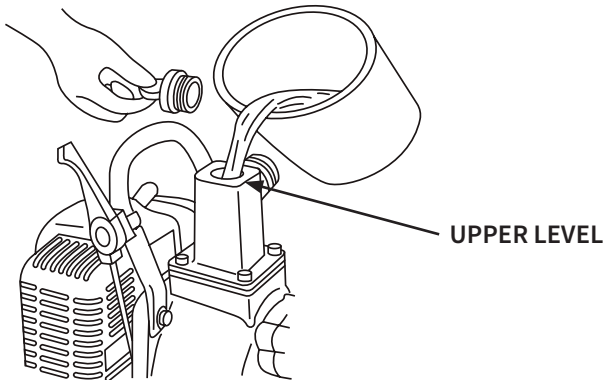

WARNING! Be sure that the pump is filled up with water before starting the engine, else mechanical seal damage will occur.

KAWASHIMA FIRE PUMP CONT.

OPERATION - THROTTLE LEVER

Pump output is controlled by adjusting the throttle lever. At maximum throttle position, the pump will deliver the highest output volume. Moving the throttle level toward the idle position will decrease the output volume of the pump.

T - Throttle Level
H - MAXIMUM
L - IDLE

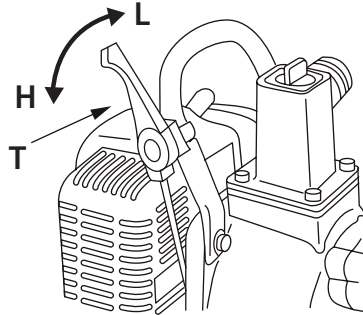

OPERATION - STOPPING ENGINE

1. Lower the throttle level fully and cool the engine down for 1-2 minutes at low speed.
2. Press the stop button to stop the engine running.

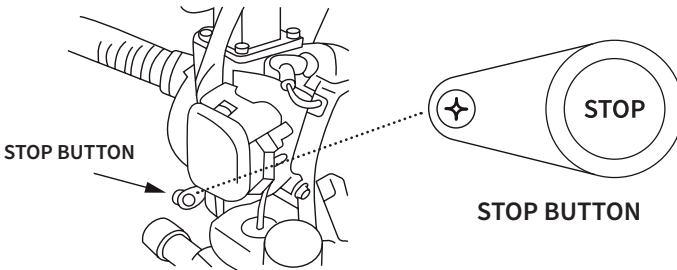

NOTE. Stop the engine immediately in the event of an emergency.

CLEANING & MAINTENANCE

Maintenance to pump and engine should be carried out regularly. Refer to pump and engine handbooks for Maintenance Schedule.

PUMP MAINTENANCE

Check pump Operators Handbook for maintenance schedule and further instructions.

- Check to make sure that all screws are tightened and that no parts are missing.
- Check to make sure there are no loose connections on hoses, nozzle, or valves.
- Thoroughly clean the nozzle.

INSPECT THE ENGINE - *All repairs to be carried out by certified Honda dealer.*

Check engine Honda Owners Manual for maintenance schedule and further instructions.

- Check to make sure there are no loose or missing screws in any part of the engine.
- Clean the air filter regularly - particularly if working in a dusty environment.
- Clean and adjust the spark plug as necessary.
- Clean the cooling fan, air intake opening and parts around the muffler.
- Check the engine oil and change it as necessary.
- Inspect the fuel line filter, check for fuel leaks.

LONG TERM CLEANING & STORAGE

- When storing the unit, ensure that it is clean and dry and kept in a ventilated place where it will not be subject to freezing temperatures. Frozen water may crack metal components and void warranty.
- Completely drain any fuel from the tank and water from the pump. (Check pump instruction manual)
- Wipe off water on the pump using dry cloth. Cover the pump and store indoors in a storage area with low-humidity.
- If operating in areas where freezing occurs we recommend leaving anti-freeze in the pump, regulator/bypass valve and handgun/nozzle while not being used to prevent possibility of frost damage.

CLEANING & MAINTENANCE cont.

MAINTENANCE SCHEDULE

Maintenance of your fire fighting unit should be carried out regularly. See below table for suggested guidelines in ensuring your unit stays at optimum performance.

ITEM	FREQUENCY	TASK
PUMP & GEARBOX	Daily	Perform visual inspection of pump: ensure screws are tight and no parts are missing.
	Daily	Check oil level in sight gauge - top up if necessary (see pump Operators Manual for oil specifications).
	As needed	Replace pump and gearbox oil (see pump Operators Manual for oil specifications).
ENGINE	Daily	Perform visual inspection of engine: ensure screws are tight and no parts are missing.
	Daily	Check oil level on dip tube - top up if necessary (see engine Operators Manual for oil specifications).
	Daily	Inspect the fuel line and filter, check for leaks or contamination.
	Weekly	Clean air filter in accordance with engine manufacturers instructions (see engine tab).
	As needed	Replace engine oil (see engine tab for frequency and oil specifications).
HOSE REEL	Daily	Check hose and fittings for leaks or excessive movement. Replace damaged fittings and clamps.
	Every 6 months	Swap hose reel end for end to spread wear and increase hose lifespan.
GENERAL FITTINGS	Daily	Clean suction filter in warm soapy water using filter brush.
	Daily	Check hose and fittings for leaks or excessive movement. Replace damaged fittings and clamps.
	Daily	

FIRE MARSHAL BREAKDOWN & PARTS

Please consult with your local Rapid Spray dealership or contact the Rapid Spray service team on 1800 011 000 before replacing / altering parts.

Any unauthorized alteration, modification, attachments or repair to equipment may void the warranty as offered on Rapid Spray product or other componentry.

Please read the Honda Engine Operators / Instruction Manual and Warranty Policy. All repairs should be carried out by a licensed Honda dealer or maintenance shop, or by any engine repair establishment or individual using parts that are “certified” to EPA standards.

Attempting to repair your Honda engine may void the warranty if engine not correctly repaired / altered.

Remember than an authorised Honda servicing dealer knows your engine best and is fully equipped to maintain and repair it. To ensure the best quality and reliability, use only new Honda Genuine parts or their equivalents for repair and replacement.



MARSHAL TANK PARTS BREAKDOWN

250L MARSHAL TANK

910 (L) x 730 (W) x 620 (H)

325L MARSHAL TANK

1040 (L) x 880 (W) x 750 (H)

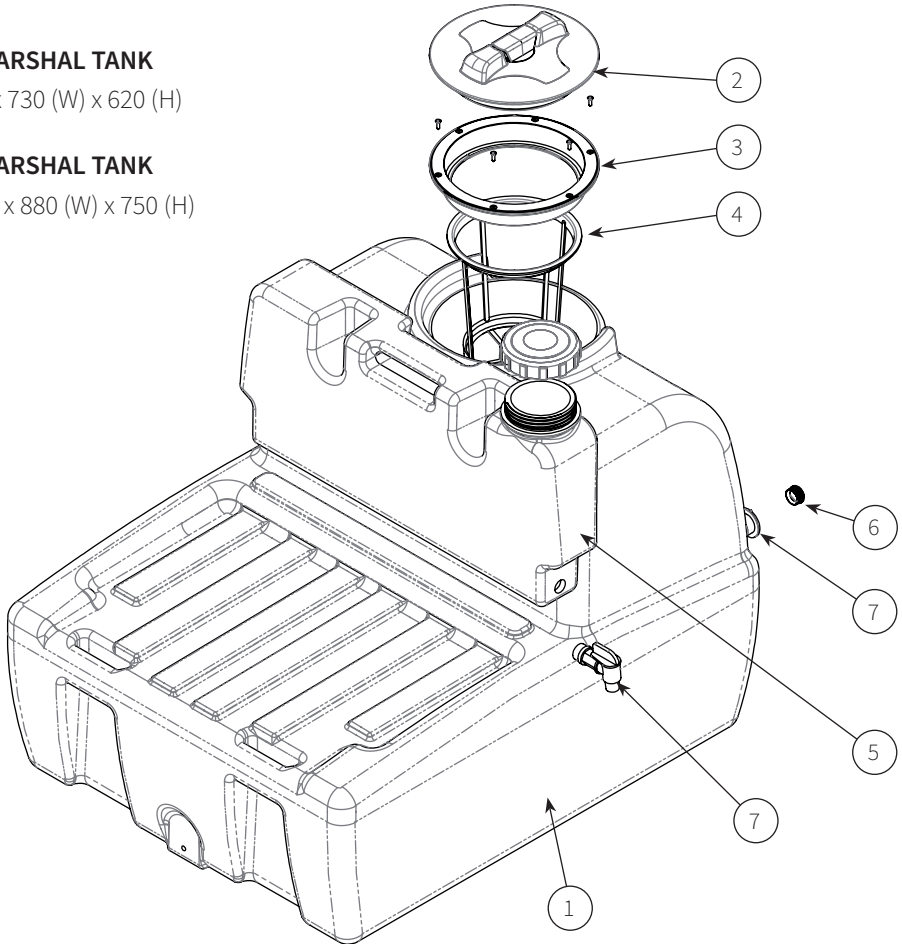

#	Part No.	Qty	Description
1	AMPTC00200ATT / 400BTT	1	200 / 400L Marshal Tank
2, 3, 4	ARLP250VSR	1	255mm Screw Lid
5	AMAXPM010BK	1	10L Rinse Tank (only Marshal Plus units)
6, 7	CFNB20M	1	3/4" poly Drain Bun & Seal
8	CFVTB20M	1	3/4 20mm Bibcock (only Marshal Plus units)

POLY FIRE FIGHTING HOSE REEL BREAKDOWN

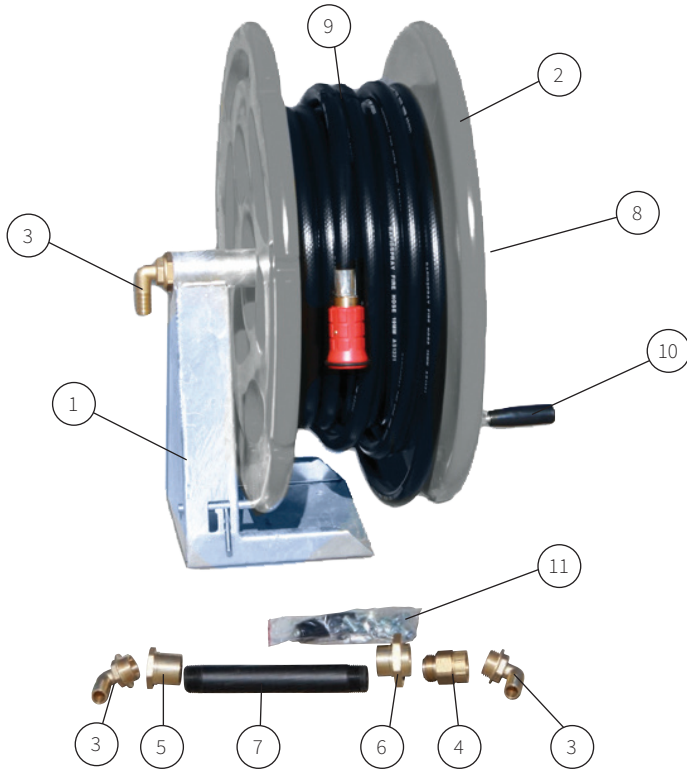

#	Parts No.	Description
1	ASR10B	Base mount frame for fire hose reel
2	AMATH100MYE	Bare hose reel
3	CFBE25M20B	1" BSP to 20mm tail brass elbow
4	CFSPB25M25F	1" BSPM to 1" BSPF brass swivel
5	CFBL25F1	Back end brass nut
6	CFBL25F2	Swivel end brass nut for hose reel
7	CFPPT25M220	25-220mm screw pipe piece poly
8	CHJCH01X100X30	Spring for FF hose reel
9	CUF14519MMX36N	36m length x 19mm fire hose with nozzle
10	CHHRB10M080	Rotating handle M10 x 80 for hose reels
11	Mounting Pack	4 x M10 Nyloc nut zinc, 4 x M10 3/8 flat washer zinc, 4 x M10 x 30 4-6 zinc set screw
12	CNAFP20F	Poly 3/4" adjustable fire fighting nozzle - to be supplied with 3/4" x 19mm hose tail

WARRANTY

WARRANTY POLICIES AND PROCEDURES

The following warranty is the only warranty applicable to RAPID SPRAY products, and to the maximum extent permitted by law, overrides any other conditions or warranties Expressed or implied on RAPID SPRAY products.

Other than legislative obligations to the contrary, RAPID SPRAY will not be liable for and incidental or consequential damages arising from the ownership or use of a product. No person, including any dealer or representative of RAPID SPRAY is authorized to make any representation or warranty on behalf of RAPID SPRAY in addition or inconsistent with these provisions. Purchasers to whom these provisions apply agree to hold RAPID SPRAY not liable for claims by their customers in excess of the obligations of RAPID SPRAY expressly set forth herein.

NOTE: All tank and spray systems must have their warranty activated by returning warranty card located at the end of this document or registering online within 21 days of purchase by the end user.

THE WARRANTY

All products sold by RAPID SPRAY are guaranteed to be free from defect in materials workmanship or manufacture for a period of 12 months from the initial date of purchase, excepting the following exclusions;

Any parts/products found by RAPID SPRAY to be defective, either in material or workmanship will be replaced or repaired within this period, at no cost to the initial purchaser if following conditions are met:

- The item has been operated in accordance with all instructions and warnings provided
- Item is still owned and operated by the original purchaser - proof of purchase is required to obtain warranty



See <https://www.rapidspray.net/resources/warranty-registration> to register your SprayScout for warranty.



The following things are expressly excluded from the above warranty.

ABUSE	Failure as a result of neglect, such as improper operation. Lack of maintenance or continued operation after discovery of a defect that leads to further damage
ALTERATIONS	Any unauthorized alteration, modification, attachments or unauthorized repair to equipment.
CLEAN-UP TIME	RAPID SPRAY does not pay for cleaning of products, parts or accessories or work area before or after the warranty repair.
DAMAGE	Damages or machine/component failure caused by carelessness/recklessness or accidental damage, improper operation, excessive speed, inappropriate storage or transportation.
ENVIRONMENTAL CONDITIONS & APPLICATION	Deteriorated or failed components such as o-rings, diaphragms, hoses, seals and connections damaged by corrosive chemicals, dirt and sand, excessive heat, moisture or other environmental impacts. Warranty determination on these type of failures will be made by RAPID SPRAY, only after inspection of the failed component.
INABILITY UNSUITABILITY	In no event shall RAPID SPRAY be liable to any person for indirect or consequential damages or for injury or commercial loss resulting from any use or inability to use any RAPID SPRAY product.
MAINTENANCE	Component failure due to failure to perform maintenance services such as, oil and grease changes/top-ups, failure to clean tanks, pumps filters, nozzles and spray lines. Failure to tighten or replace loose or missing bolts, nuts, fittings, shields and covers.
NON-GENUINE PARTS	Use of parts other than RAPID SPRAY parts for repair of warranted items will automatically negate any warranty. Warranted components must be replaced with genuine parts.

This page has been left blank intentionally.

WARRANTY REGISTRATION

You can register online at www.rapidspray.net/resources/warranty-registration or complete all the details below and post this form back to:

Rapid Spray, PO Box 3119, Singleton NSW 2330

Model Serial No

Purchased From
(Dealer Name & Town)

Purchaser's Name

Purchaser's Address

Purchaser's Phone Number

Email Address:

Disclaimer: If you don't want us to keep you informed of new products, please tick the following circle:

To help us help you further, please complete the following:

Purchaser's Age

- Up to 25
- 25 - 40
- 41 - 55
- Over 55

Principal Usage

- Commercial farm
- Hobby farm
- Industrial
- Other.....
- Town council
- Hire company
- Home

What influenced you to purchase a Rapid Spray product?

- Received Catalogue
- Newspaper advertisement
- Magazine advertisement
- Dealer recommendation
- Friends recommendation
- Better features than competitor product
- Quality & reliability
- Price
- Past experience with Rapid Spray products
- Other.....

What other Rapid Spray products do you use?

- Hand / Backpack Sprayers
- Cartage / Spray tanks
- Diesel refuelling units / tanks
- Fire fighting
- UTV / Field sprayers
- Pumps, motors and controllers
- Chapin / Jacto sprayers
- Other.....



This page has been left blank intentionally.



Call us on 1800 011 000 or
visit www.rapidspray.net

35 Enterprise Cres, Singleton NSW 2330
PO BOX 3119 Singleton NSW 2330

Telephone: 1800 011 000
Facsimile: 02 6571 2951

Rapid Spray Liquid Management Systems

