



SPOT RANGER HP

OPERATORS HANDBOOK



SPOT RANGER HP SPRAYER

60L / 95L



CONTENTS

- 01** Introduction
- 02** Warnings
- 03** Product Risk Assessment
- 04** Assembly
- 04** Operation
- 05** Mixing & Filling
- 05** Spraying
- 07** Calibration Guidelines for Spray Guns
- 08** Maintenance
- 09** Exploded Diagram of all Models
- 10** RapidLine Pump Breakdown
- 11** Spray Gun Breakdown
- 12** Accessories
- 13** Warranty
- 15** Warranty Registration



INTRODUCTION

Congratulations on your purchase of a Rapid Spray 12V Spot Ranger HP Sprayer which has been designed for effortless spraying of herbicides and pesticides.

The design of the tank enables the unit to be mounted onto the cargo rack of an ATV or on the back of a utility vehicle, trailer or tractor or such like vehicle.

MODEL

Please note your unit may not have all the parts or accessories listed in this handbook. **This handbook covers the following model** (including any custom variations):



Example Codes:
SVR0060L0040
SVR0095L0068

DISCLAIMER: In line with our policy of continuous improvement, the weights, dimensions and design may change slightly from what is shown in this operators handbook.

***WARNING:** Always obey vehicle and UTV/ATV manufacturer instructions regarding loading and operation. Please check weight restrictions. Serious death or injury can occur from improper usage. Rapid Spray accepts no liability for the unsafe operation of this unit.

WARNINGS

1. When mounting to any vehicle ensure that you have read the Vehicle Owner's Manual and that you comply with all the weight restrictions as specified by the vehicle manufacturer, as overloading can cause injury or death.
2. To ensure your own safety and that of your employees if applicable you must comply with all relevant environmental, work place health and safety legislation and codes of practice.
3. Select and wear appropriate Personal Protection Equipment in accordance with the label of the product you intend using and your own safe work practices.
4. Care should be taken when spraying in windy conditions as spray drift may contaminate the air and may effect the operator or damage adjacent non-target vegetation.
5. Once the spraying operation has been completed, decontaminate the spray tank and spray accessories. Dispose of rinsing's in compliance with current environmental, work place health and safety regulations.
6. Personal Protection Equipment must still be worn while decontaminating your hose reel as per warning at 3 above.



PRODUCT RISK ASSESSMENT

TASK	HAZARDS	RISK	CONTROL MEASURES
1. Partially fill the tank with water, connect the battery (if applicable) and test the spray unit.	Manual handling; slips, trips or falls; finger jammed; electric shock or electrocution.	Medium	Concentrate on tasks; follow safe manual handling techniques: - don't lift on your own if > 20kg, bend knees & keep back straight; keep fingers clear; keep unit at least 8m way from overhead power lines; ensure AS 3760:2001 Testing Electrical Equipment applies; water away from electrical sources.
2. Check weather and weather and select the appropriate PPE to suit the chemicals to be used.	Manual handling; slips, trips and falls.	Low	Put on PPE as per the chemical requirements in the Material Safety Data Sheet - coveralls, gloves, safety, footwear, glasses and respirator; follow safe manual handling procedures: don't lift on your own if > 20kg, bend knees and keep back straight.
3. Mix chemicals and fill spray tank units.	As above; spray drift, chemical spillage, emission of vapours or flammability; weather; untrained visitors.	Medium	As above; user trained in the state's chemical mixing & administration course e.g. Chem Cert; follow the relevant Environment Protection Authority requirements, fire extinguisher present; keep visitors away from the job unless wearing full PPE.
4. Use spray unit.	As above; loss of load; work in heat and cold; noise; exceed load limit of vehicle; hose entanglement; terrain and slopes	High	As above; wear clothes to suit heat & cold; wear hearing protection if pump noise > 85 dBA; follow manufacturer's safe operation instructions for the vehicle & the spray unit; don't overload-water weighs 1kg per 1 litre; secure load to vehicle; hose tidy.
5. Clean up, maintenance and storage.	As above.	Low	As above; continue to wear PPE for clean up, store tank in a dry, well ventilated area.

ASSEMBLY

The following steps are given as a guide to assemble your spot sprayer:

1. Check inside tank for any foreign objects.
2. Remove hose wraps, screws clamps, bungee cords and gauge from parts bag.
3. Install hose wraps and bungee cords using screws provided, taking care not to over tighten the screws.
4. Attach hose to the discharge port of the regulator using worm drive clamp provided.
5. Install drain bung.
6. Fit lid on top of tank.

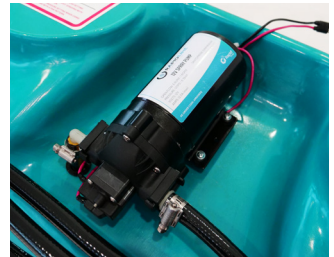

OPERATION

The following steps are given as a guide to operate your Spot Ranger HP sprayer.

- When mounting sprayer to vehicle using a ratchet tie-down strap, check that the spray tank is still secure after the first 15 minutes of operation and re-tighten if necessary.
- Partially fill the tank with clean water.
- Connect the battery clips to a 12V DC power supply (red to positive terminal, black to negative terminal) ensuring sufficient current capability (amps) to suit the pump. The pump's maximum amperage requirement is shown on its name plate.
- In order to prime the system and enable the pump to reach full pressure, depress the hand lance trigger to release trapped air. The pump may automatically switch off when the hand lance trigger is released.
- Pump cycling may occur with insufficient nozzle delivery. This continual switching on and off will reduce battery and motor life. Should this occur, adjust the setting of the nozzle tip or the regulator until the cycling stops.

MIXING & FILLING

The following steps are given as a guide to mixing and filling your Spot Ranger HP sprayer.

- Read the product and follow the instructions carefully, taking special note with regard to the order in which the products are added to the tank.
- Calibrate the sprayer according to recognized calibration method using water only. Calibration must be done with the nozzle tip that has been selected for the spraying task.
- Measure out the correct quantity of pesticides using clean measuring jugs used only for this purpose.
- Half fill the sprayer with clean water then add the measured pesticide.
- Rinse out the measuring jug and empty container and pour all rinsing's into the spray tank. Agitate by stirring with a suitable round edged paddle.
- Top up the tank with water to the required level, ensure that the tank is not over-filled and the outside is clean and dry before handling.
- Safely dispose of empty containers in compliance with current regulations.
- Mixing sites must be well away from watercourses and other environmental sensitive areas. Children and animals must be kept away.

SPRAYING

The following steps are given as a guide to spraying with your Spot Ranger HP sprayer.

PLANNING TO SPRAY SAFELY

- Before commencing spraying, plan the work effectively to reduce potential contamination.
- Wind direction and speed must be taken into account. Avoid spraying on still, hot and sunny days or when wind speed exceeds 6.5km/h.
- Do not spray if the operator, bystanders, watercourses or any non-target vegetation appears to be in danger from spray drift contamination.
- Drift can be reduced by lower nozzle height, lower pressures or by fitting larger nozzles.

SPRAYING CONT.

SETTING UP YOUR SPRAYER

To begin, turn on the pump and activate the trigger or boom valve. Turn off the hand wand/boom valve and check to ensure the pump is not turning rapidly on & off or cycling. If the pump is cycling, you will need to reduce the spraying pressure slightly until this stops.

WHEN SPRAYING

- Spraying at a constant speed (as used during calibration) and shut off the hand lance trigger at the end of each swath or before changing direction.
- Work in parallel lines at the correct spacing when spraying large area – this is better than moving the hand lance from side to side in a swinging movement which causes damage by overdosing.



CALIBRATION GUIDELINES FOR SPRAY GUNS

Non-calibrated spray nozzles can lead to inaccurate application rates, spray patterns and droplet size, which can reduce herbicide effectiveness. The first and most important step in sprayer calibration is to choose the correct nozzle type and size for your application.

NOZZLES AND PRESSURES FOR DIFFERENT SPRAY VOLUMES

Prior to spraying, select a bush to spray and decide what shape the weed can be categorized as (either dome or cylindrical). Spray that bush normally to achieve good coverage to the point of run-off. Time how long it took you to spray. Repeat this process spraying into a bucket. Measure the spray volume and compare this with the recommended spray and water rate using the tables attached.

SPRAY VOLUME	NOZZLE	DIAMETER	OUTPUT	PRESSURE	PSI
	(L/ha)	(mm)	(L/min)	(kpa)	
1000 - 2000	D4	1.6	2.5	400	57
1500 - 3000	D5	2.0	3.8	500	71
2000 - 4000	D6	2.4	5.5	600	85
3000 - 6000	D7	2.8	7.8	700	100
4000 - 8000	D8	3.2	8.6	800	114



MAINTENANCE

The following steps are given as a guide to maintain your Spot Ranger HP:

- After use, the sprayer must be thoroughly decontaminated including tank, pump, hoses and hand lance to avoid damage to crops from harmful spray residue and to the sprayer from corrosion or abrasion.
- After spraying, flush the tank, hose and hand lance by running it with clean water plus a recommended cleaning fluid. It is best to clean sprayers in the field or area just treated.
- The suction strainer attached to the pump suction line should be cleaned periodically. Unscrew lid, remove filter and flush with clean running water.
- Nozzle filters (if fitted), nozzle tips, nozzle caps and gaskets should be cleaned by soaking in water, brushing with a nozzle brush and allowed to dry. Never blow through nozzles with your mouth, nor use wire or pins to clear any blockages.
- When storing your spot sprayer ensure that it is clean and dry and kept in a well ventilated place.



EXPLODED DIAGRAM OF ALL MODELS

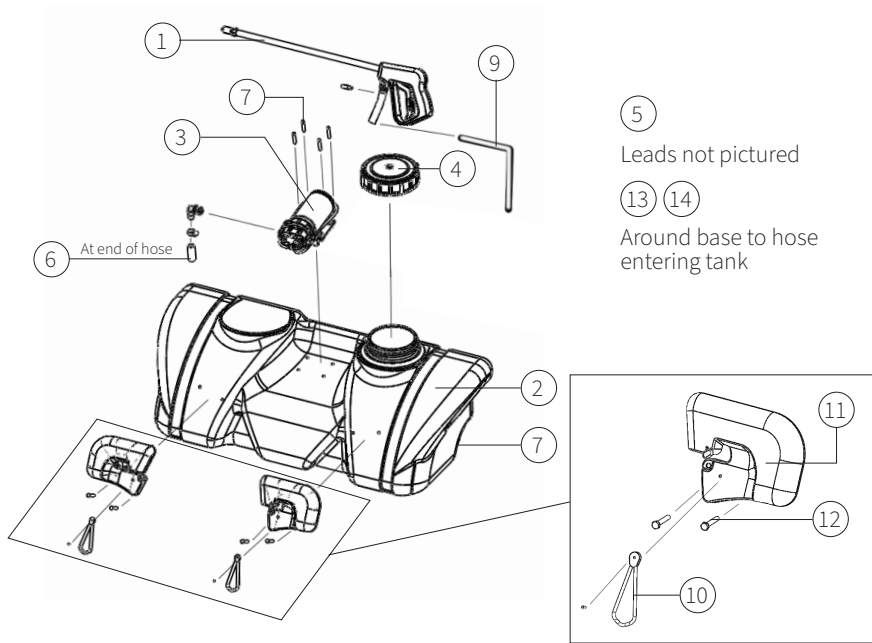

For all SVR models 60L - 95L with 12V RapidLine pump.

NB: tank pictured is not indicative of every model, but basic equipment is the same.

ITEM	DESCRIPTION	PART NO.	QTY	ITEM	DESCRIPTION	PART NO.	QTY
1	Powerjet spray gun (700mm)	AHG110T	1	8	3/4 inch drain bung	CFNB20M	1
2	60L Spot Ranger 95L Spot Ranger	AMPTC00060TT AMPTC00095TT	1	9	10mm spray hose		6
3	RapidLine 12V pump: 6.8L/min 120 psi 4.0L/min 70psi	APR0068Q APR0040	1	10	Bungy Loop (200mm nominal length)	CHYL210MM	2
4	150mm screw lid	ARLP150AV	1	11	Hose wrap for Spot Ranger	CHKHPX2	SET
5	2.4m 12V electrical leads		1	12	M6 x 30 pan Phillips metal thr zinc		
6	Suction foot filter (10mm)	ATPFFB10	1	13	5/8 inch top hat grommet	CYGTE15	1
7	M5 x 25 pan Phillips metal thr zinc	CHLM05M025Z	4	14	3/4 inch top hat grommet	CYGTE20	1

RAPIDLINE 6.8L/MIN 120 PSI PUMP BREAKDOWN

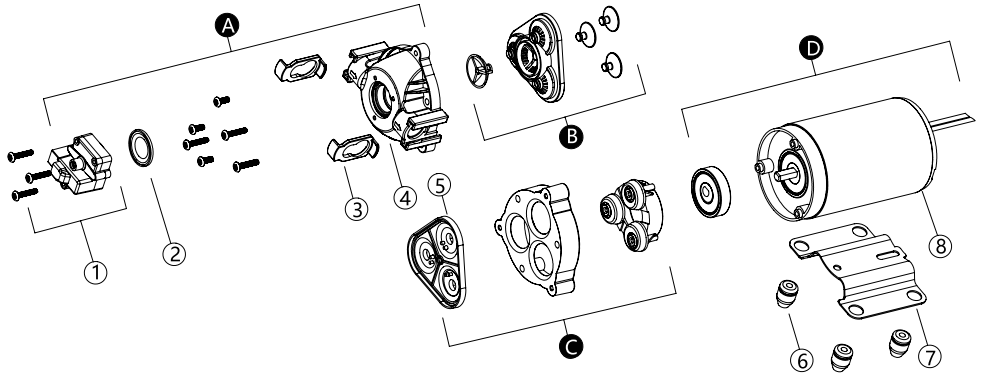

ITEM	DESCRIPTION	QTY
A	Pump Head Assembly	1
B	Valve Assembly	1
C	Diaphragm Assembly	1
D	Motor Assembly	1
1	Pressure Switch	1
2	Diaphragm of Pressure Switch	1

ITEM	DESCRIPTION	QTY
3	Quick Attach Clip	2
4	Pump Head	1
5	Diaphragm	1
6	Rubber Feet	4
7	Iron Base Plate	1
8	Motor	1

RAPIDLINE 4.0L/MIN 70 PSI PUMP BREAKDOWN

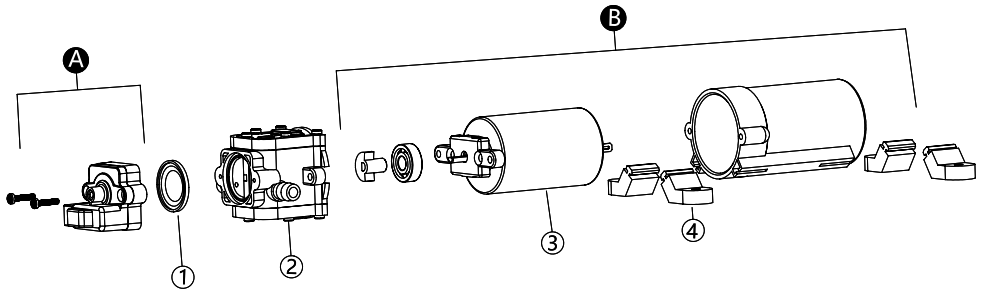

ITEM	DESCRIPTION	QTY
A	Pressure Switch	1
B	Motor Assembly	1
1	Diaphragm of Pressure Switch	1

ITEM	DESCRIPTION	QTY
2	Pump Head Assembly	1
3	Motor	1
4	Rubber Feet	4

SPRAY GUN BREAKDOWN

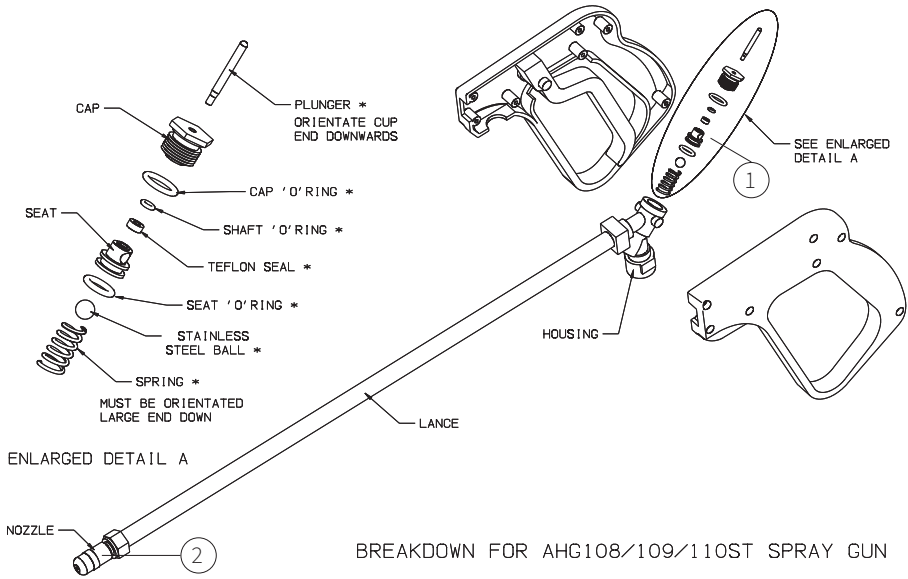

BREAKDOWN FOR AHG108/109/110ST SPRAY GUN

ITEM	DESCRIPTION	PART NO.	QTY
1	Repair kit to suit AHG108, AHG109, AHG110 and AHG111 Powerjet spray guns	CPLK108R	SET
2	Brass nozzle to suit AHG108, AHG109, AHG110, AHG111 and AHG112 Powerjet/Rapidjet spray guns	CPLP108N	1

* Are included in CPLK108R repair kit

ACCESSORIES



ZERO TURN TRAILER KIT - ATK055095TZ

- Long drawbar for extra sharp turning up to 90°
- Excellent ground clearance with wide track for greater stability
- Sturdy powder coated steel frame with 10° pneumatic tyres
- Compatible with 60L and 95L
- Three sizes: 2m, 3m and 4m spray width



ATV MOUNTING KIT - ATK055095A

- Easy ATV mounting system with 90° angle design with versatility
- Powder coated steel construction guarantees superior load bearing

BOOMS - ABS020, ABS030, ABS040

- Three sizes: 2m, 3m and 4m spray width
- Fitted with deflector type spray nozzles at 1m spacings
- 3m and 4m booms have spring loaded positive action breakaway and vertical fold capacity
- Powder coated steel construction
- Some assembly required

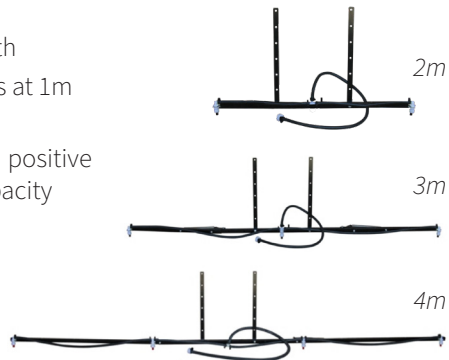

WARRANTY

WARRANTY POLICIES AND PROCEDURES

The following warranty is the only warranty applicable to RAPID SPRAY products, and to the maximum extent permitted by law, overrides any other conditions or warranties Expressed or implied on RAPID SPRAY products.

Other than legislative obligations to the contrary, RAPID SPRAY will not be liable for and incidental or consequential damages arising from the ownership or use of a product. No person, including any dealer or representative of RAPID SPRAY is authorized to make any representation or warranty on behalf of RAPID SPRAY in addition or inconsistent with these provisions. Purchasers to whom these provisions apply agree to hold RAPID SPRAY not liable for claims by their customers in excess of the obligations of RAPID SPRAY expressly set forth herein.

NOTE: All tank and spray systems must have their warranty activated by returning warranty card located at the end of this document within 21 days of purchase by the end user.

THE WARRANTY

All products sold by RAPID SPRAY are guaranteed to be free from defect in materials workmanship or manufacture for a period of 12 months from the initial date of purchase, excepting the following exclusions;

Any parts/products found by RAPID SPRAY to be defective, either in material or workmanship will be replaced or repaired within this period, at no cost to the initial purchaser if following conditions are met:

- The item has been operated in accordance with all instructions and warnings provided
- Item is still owned and operated by the original purchaser - proof of purchase is required to obtain warranty



The following things are expressly excluded from the above warranty.

ABUSE	Failure as a result of neglect, such as improper operation. Lack of maintenance or continued operation after discovery of a defect that leads to further damage
ALTERATIONS	Any unauthorized alteration, modification, attachments or unauthorized repair to equipment.
CLEAN-UP TIME	RAPID SPRAY does not pay for cleaning of products, parts or accessories or work area before or after the warranty repair.
DAMAGE	Damages or machine/component failure caused by carelessness/recklessness or accidental damage, improper operation, excessive speed, inappropriate storage or transportation.
ENVIRONMENTAL CONDITIONS & APPLICATION	Deteriorated or failed components such as o-rings, diaphragms, hoses, seals and connections damaged by corrosive chemicals, dirt and sand, excessive heat, moisture or other environmental impacts. Warranty determination on these type of failures will be made by RAPID SPRAY, only after inspection of the failed component.
INABILITY UNSUITABILITY	In no event shall RAPID SPRAY be liable to any person for indirect or consequential damages or for injury or commercial loss resulting from any use or inability to use any RAPID SPRAY product.
MAINTENANCE	Component failure due to failure to perform maintenance services such as, oil and grease changes/top-ups, failure to clean tanks, pumps filters, nozzles and spray lines. Failure to tighten or replace loose or missing bolts, nuts, fittings, shields and covers.
NON-GENUINE PARTS	Use of parts other than RAPID SPRAY parts for repair of warranted items will automatically negate any warranty. Warranted components must be replaced with genuine parts.

WARRANTY REGISTRATION

You can register online at www.rapidspray.net/resources/warranty-registration or complete all the details below and post this form back to:

Rapid Spray, PO Box 3119, Singleton NSW 2330

Model Serial No

Purchased From
(Dealer Name & Town)

Purchaser's Name

Purchaser's Address

Purchaser's Phone Number

Email Address:

Disclaimer: If you don't want us to keep you informed of new products, please tick the following circle:

To help us help you further, please complete the following:

Purchaser's Age

- Up to 25
- 25 - 40
- 41 - 55
- Over 55

Principal Usage

- Commercial farm
- Hobby farm
- Industrial
- Other.....
- Town council
- Hire company
- Home

What influenced you to purchase a Rapid Spray product?

- Received Catalogue
- Newspaper advertisement
- Magazine advertisement
- Dealer recommendation
- Friends recommendation
- Better features than competitor product
- Quality & reliability
- Price
- Past experience with Rapid Spray products
- Other.....

What other Rapid Spray products do you use?

- Compact/Field Sprayer
- Cartage or Spray tanks
- Diesel tanks
- Fire fighting
- 3PL Sprayers
- Pumps, parts or accessories
- Compression or Knapsack sprayers
- Other.....



This page has been left blank intentionally.



Call us on 1800 011 000 or
visit www.rapidspray.net

35 Enterprise Cres, Singleton NSW 2330
PO BOX 3119 Singleton NSW 2330

Telephone: 1800 011 000
Facsimile: 02 6571 2951

Rapid Spray Liquid Management Systems



AYH015